

slim

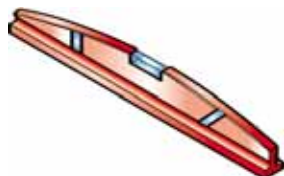

Copyright by Fontanot S.p.A., first publication April 23, 2014

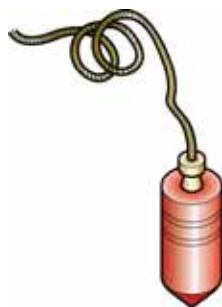

2 mm
2,5 mm
3 mm
4 mm

5 mm
6 mm
12 mm

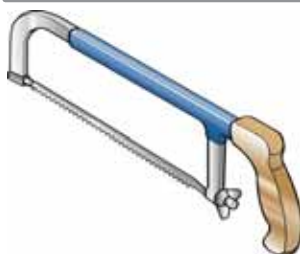

PH 2



13 mm
30 mm

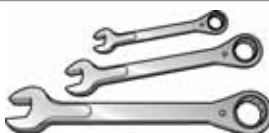

13 mm
17 mm
30 mm



Ø 8 x 120 mm
Ø 14 x 150 mm

1

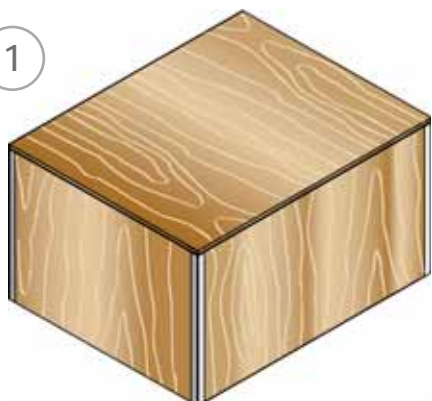

2

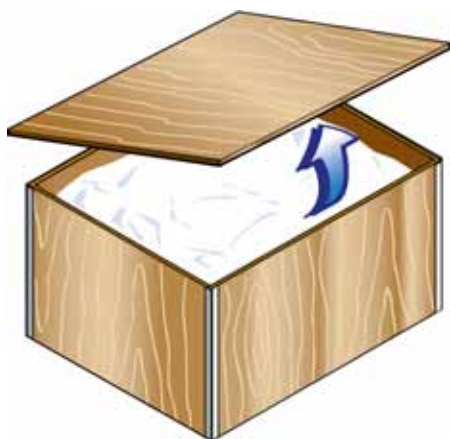

3



10	11	12	13	14	15	16
3	3	3	3	3	3	3

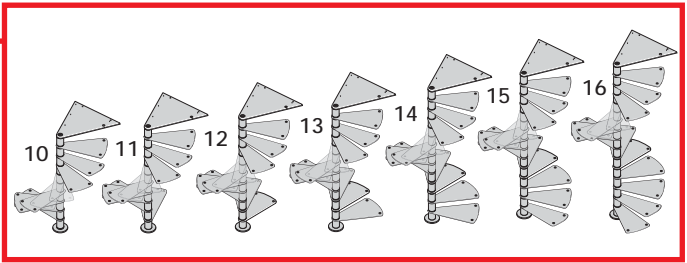
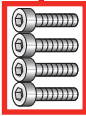

A28



10	11	12	13	14	15	16
20	25	25	25	30	30	30

A41



10	11	12	13	14	15	16
15	20	20	20	25	25	25

A47



10	11	12	13	14	15	16
10	10	10	12	12	12	14

A48



10	11	12	13	14	15	16
8	8	8	8	8	8	8

A52



10	11	12	13	14	15	16
4	4	4	4	4	4	4

A53



10	11	12	13	14	15	16
1	1	1	1	1	1	1

B02



10	11	12	13	14	15	16
12	12	12	12	12	12	12

B03



10	11	12	13	14	15	16
2	2	2	2	2	2	2

B04



10	11	12	13	14	15	16
1	1	1	1	1	1	1

B06



10	11	12	13	14	15	16
4	4	4	4	4	4	4

B08



10	11	12	13	14	15	16
5	5	5	5	5	5	5

B12



10	11	12	13	14	15	16
7	7	7	7	7	7	7

B17



10	11	12	13	14	15	16
1	1	1	1	1	1	1

B23



10	11	12	13	14	15	16
4	4	4	4	4	4	4

B30



10	11	12	13	14	15	16
3	3	3	3	3	3	3

B46



10	11	12	13	14	15	16
2	2	2	2	2	2	2

B47



10	11	12	13	14	15	16
1	1	1	1	1	1	1

BA8



10	11	12	13	14	15	16
2	2	2	2	2	2	2

BD3



10	11	12	13	14	15	16
1	1	1	1	1	1	1

BD4



10	11	12	13	14	15	16
1	1	1	1	1	1	1

BD5



10	11	12	13	14	15	16
15	16	17	18	19	20	21

BD6



10	11	12	13	14	15	16
10	11	12	13	14	15	16

BD7



10	11	12	13	14	15	16
19	21	23	25	27	29	31

BD8



10	11	12	13	14	15	16
1	1	1	1	1	1	1

BD9



10	11	12	13	14	15	16
3	3	3	3	3	3	3

BG5



10	11	12	13	14	15	16
2	2	2	2	2	2	2

BN7



10	11	12	13	14	15	16
2	2	2	2	2	2	2

BR1



10	11	12	13	14	15	16
20	20	20	20	20	20	20

C49



10	11	12	13	14	15	16
2	2	2	2	2	2	2

C50



10	11	12	13	14	15	16
2	2	2	2	2	2	2

C58



10	11	12	13	14	15	16
7	7	7	7	7	7	7

C76



10	11	12	13	14	15	16
45	45	45	45	45	45	45

C77



10	11	12	13	14	15	16
55	60	65	70	75	80	85

C79



10	11	12	13	14	15	16
15	16	17	18	19	20	21

CA8



10	11	12	13	14	15	16
5	5	5	5	5	5	5

CB5



10	11	12	13	14	15	16
5	5	5	5	5	5	5

CC9



10	11	12	13	14	15	16
3	3	3	3	3	3	3

CD8



10	11	12	13	14	15	16
4	4	4	4	4	4	4

CE4

H = 1090 mm



10	11	12	13	14	15	16
10	11	12	13	14	15	16

CE6

H = 910 mm



10	11	12	13	14	15	16
5	5	5	5	5	5	5

CF9



10	11	12	13	14	15	16
15	16	17	18	19	20	21

CG1



10	11	12	13	14	15	16
8	8	8	10	10	10	12

CG2



10	11	12	13	14	15	16
15	16	17	18	19	20	21

CG3



10	11	12	13	14	15	16
15	16	17	18	19	20	21

CG4



10	11	12	13	14	15	16
3	3	3	3	3	3	3

D01



10	11	12	13	14	15	16
4	4	4	4	4	4	4

D39



10	11	12	13	14	15	16
55	60	65	70	75	80	85

D40



10	11	12	13	14	15	16
20	20	20	20	20	20	20

D45



10	11	12	13	14	15	16
60	66	72	78	84	90	96

D47



10	11	12	13	14	15	16
10	11	12	13	14	15	16

D75



10	11	12	13	14	15	16
20	20	20	20	20	20	20

E02



10	11	12	13	14	15	16
1	1	1	1	1	1	1

F09



10	11	12	13	14	15	16
2	2	2	2	2	2	2

F20



10	11	12	13	14	15	16
5	5	5	5	5	5	5

F33



10	11	12	13	14	15	16
4	4	4	4	4	4	4

F34



10	11	12	13	14	15	16
6	6	6	6	6	6	6

F35



10	11	12	13	14	15	16
15	16	17	18	19	20	21

F44



10	11	12	13	14	15	16
2	2	2	2	2	2	2

F55



10	11	12	13	14	15	16
15	16	17	18	19	20	21

G02 H = 820 mm



10	11	12	13	14	15	16
2	1	1	0	0	1	1

G02 H = 1250 mm



10	11	12	13	14	15	16
0	1	1	2	2	2	2

G03



10	11	12	13	14	15	16
1	1	1	1	1	1	1

G09



10	11	12	13	14	15	16
1	1	1	1	1	1	1

L03



10	11	12	13	14	15	16
9	10	11	12	13	14	15

X01





IT) ATTENZIONE!

Leggere e seguire scrupolosamente queste istruzioni e tenere per future consultazioni.

Eseguire l'installazione "a regola d'arte", utilizzando attrezzi idonei; seguire scrupolosamente le istruzioni di montaggio. Informarsi prima dell'installazione, sui regolamenti locali e nazionali da rispettare, in funzione della destinazione d'uso (privato principale, secondario, uffici, negozi,...).

EN) WARNING!

Carefully read and strictly follow these instruction and keep them for future consultation.

Carry out the installation in a "workmanlike" manner, strictly following the installation instructions and using suitable tools. Always consult your local building department for code requirements that must be respected depending on its destination of use (private, secondary, public...).

DE) ACHTUNG!

Lesen sie diese Anleitung sorgfältig durch und heben sie sie für spätere Zwecke auf.

Die Montage muss fachgerecht, unter Zuhilfenahme geeigneter Hilfsmittel und unter strikter Einhaltung der Montageanleitung ausgeführt werden. Damit die Montage normgerecht erfolgen kann, muss man zuvor Informationen zur Aufstellung und zu den lokal und national geltenden Vorschriften je nach Bestimmungszweck (privat, Haupt- oder Nebeneinrichtung, Büros, Geschäfte, ...) einholen.

FR) ATTENTION !

Lire et respecter scrupuleusement les présentes instructions ; les conserver pour toute autre consultation.

Effectuer l'installation dans les règles de l'art en utilisant des outils appropriés ; suivre scrupuleusement les instructions de montage. Pour réaliser un montage conforme aux normes en vigueur, il faut s'informer avant l'installation quant aux réglementations locales et nationales à respecter, en fonction du domaine d'utilisation (résidence privée principale, secondaire, bureaux, magasins,...).

ES) ¡ATENCIÓN!

Leer y seguir estrictamente estas instrucciones y conservarlas para consultas futuras.

Realizar la instalación "según las reglas del arte", utilizando herramientas adecuadas; seguir estrictamente las instrucciones de montaje. Informarse antes de la instalación sobre los reglamentos locales y nacionales a respetar, en función del destino de uso (privado principal, secundario, oficinas, tiendas,...).



SV) OBSERVERA!

Läs och följ noggrant dessa anvisningar och spara dem för framtida konsultation.

Utför installationen på ett yrkesmannamässigt sätt med lämpliga verktyg. Följ monteringsinstruktionerna i detalj. Informera dig före installationen om lokala och nationella bestämmelser som ska respekteras, beroende på avsett användningsområde (privat, offentlig, kontor, butiker o.s.v.).

DA) ADVARSEL!

Læs og overhold nøje disse anvisninger og opbevar dem til efterfølgende henvisninger.

Installationen skal udføres i overensstemmelse med bedste praksis, ved brug af egnede redskaber; følg omhyggeligt monteringsinstruktionerne. Hent oplysninger før installationen angående de lokale og nationale bestemmelser, der skal overholdes afhængigt af den påtænkte anvendelse (privat hovedbrug, privat sekundær brug, kontorer, butikker,....).

NO) ADVARSEL!

Les og følg bruksanvisningen nøye og oppbevar den for senere bruk.

Produktet må installeres "etter alle kunstens regler" og med passende verktøy. Følg monteringsbeskrivelsen nøye. Informer deg om eventuelle lokale og nasjonale forskrifter som gjelder for ditt spesielle bruksområde (primær eller sekundær privat bruk, kontorer, forretninger osv.) før du installerer produktet.

FI) VAROITUS!

Lue ja noudata huolellisesti näitä ohjeita ja säilytä ne tulevaa tarvetta varten.

Suorita asennus kunnolla käyttäen asianmukaisia välineitä; noudata huolellisesti asennusohjeita. Tutustu ennen asennusta voimassa oleviin paikallisiin ja kansallisiin määräyksiin, käyttökohteen mukaan (yksityinen pääasiallinen, toissijainen, toimisto, kaupat,...).

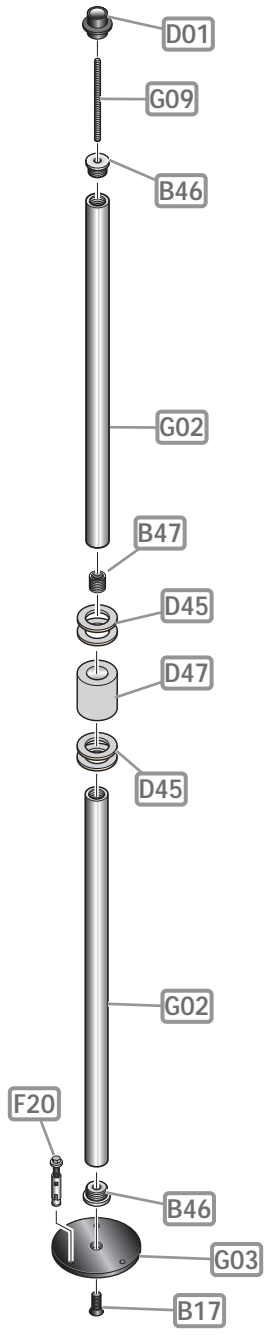

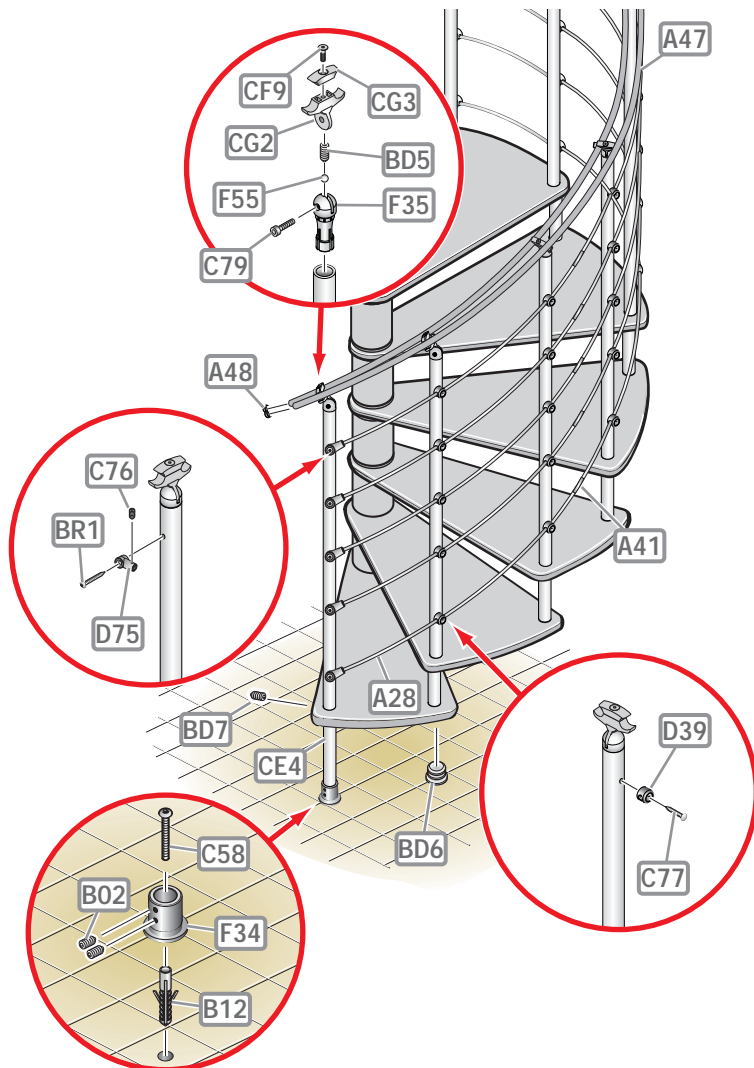

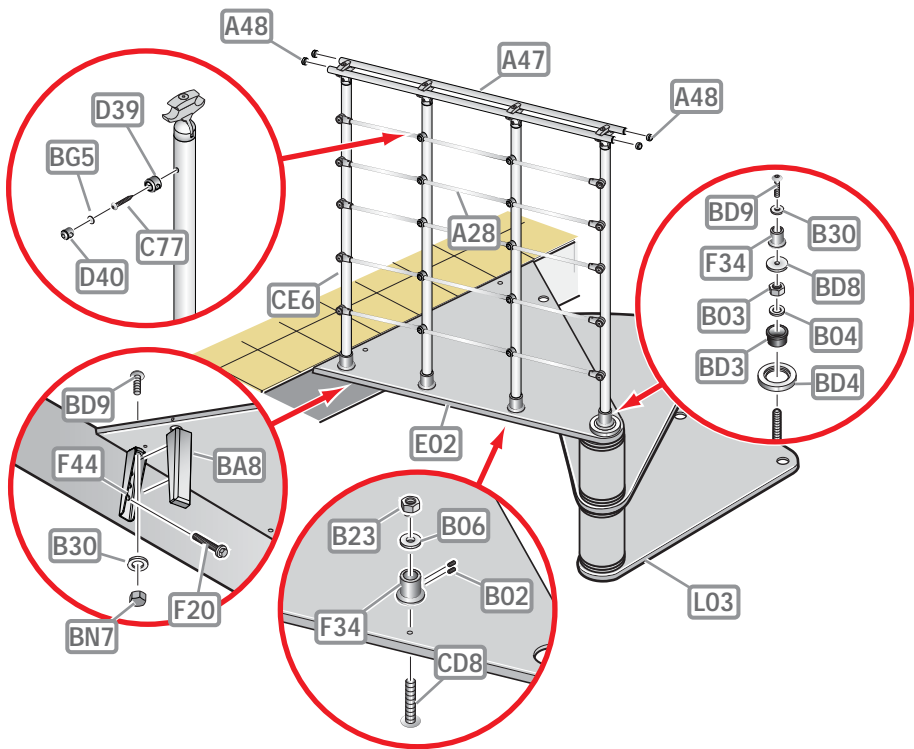

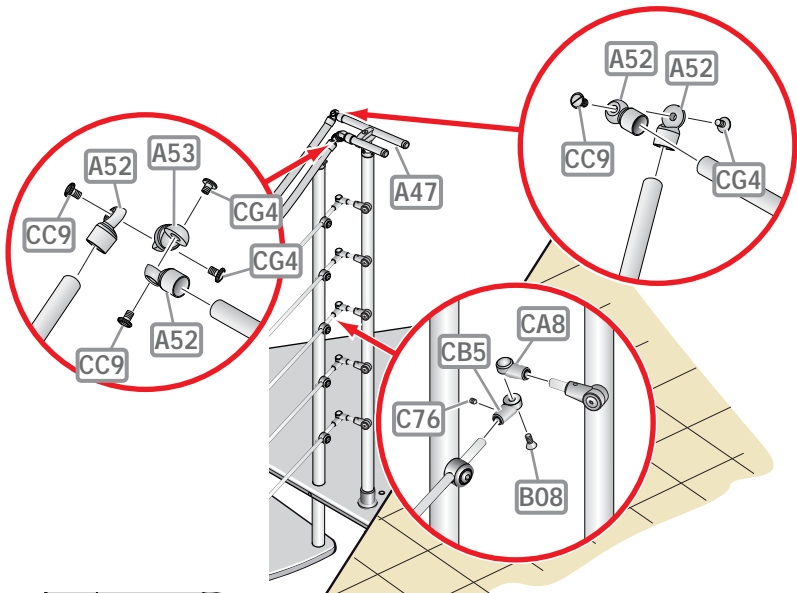

4

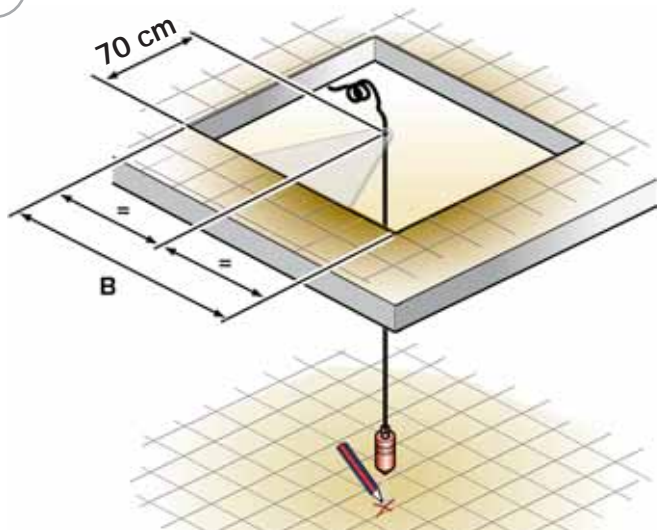

5

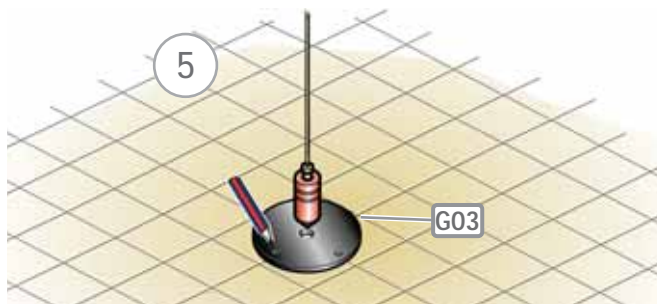

6

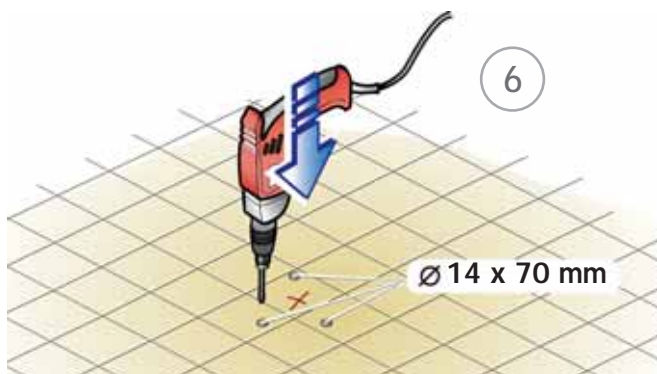

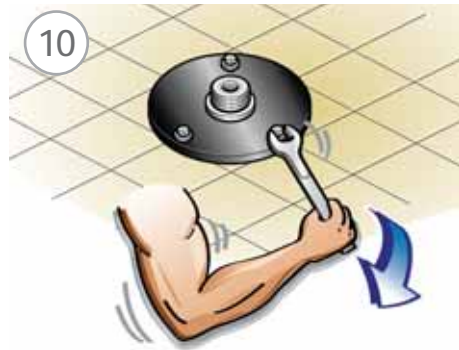
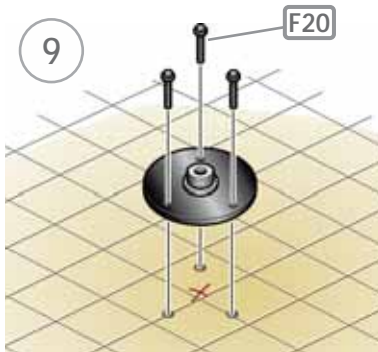
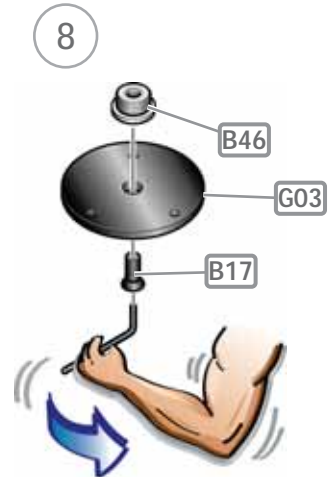
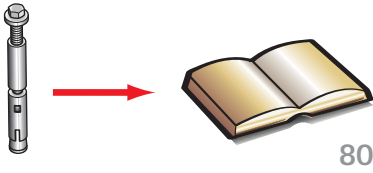
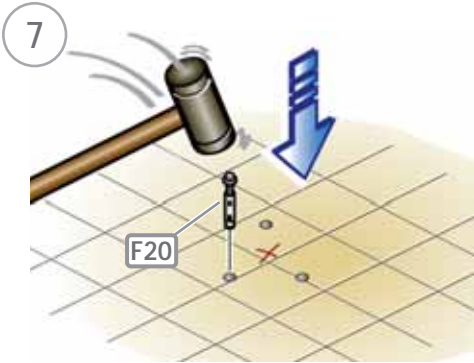

11

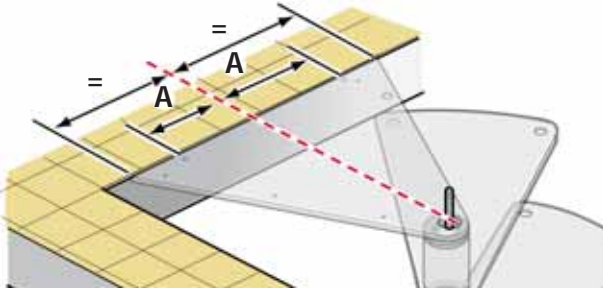

12

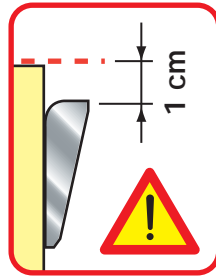
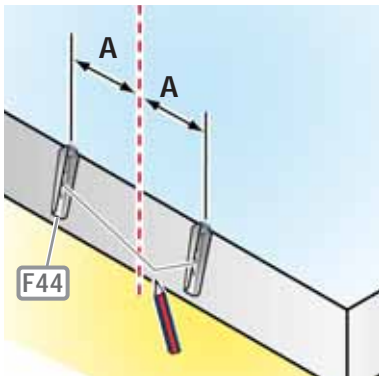

13

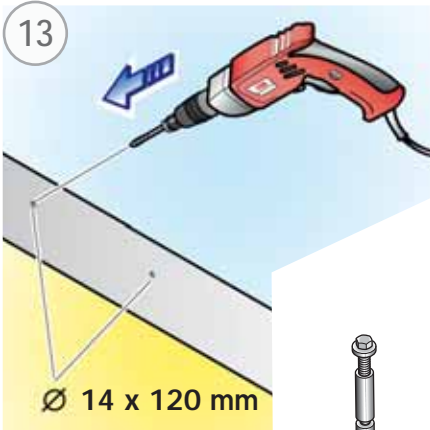

14

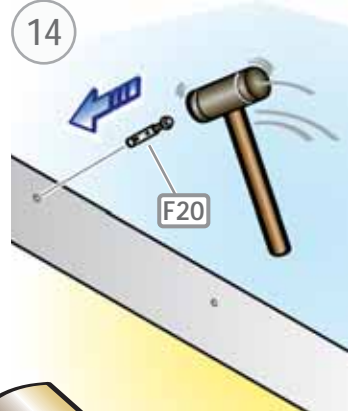

80

15

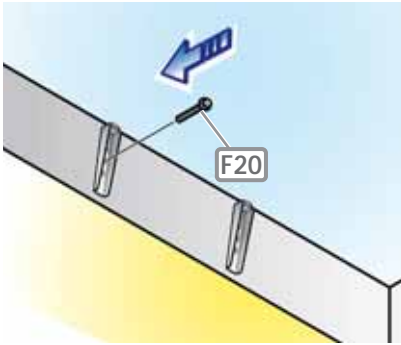

16

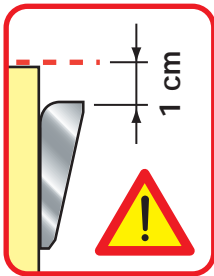
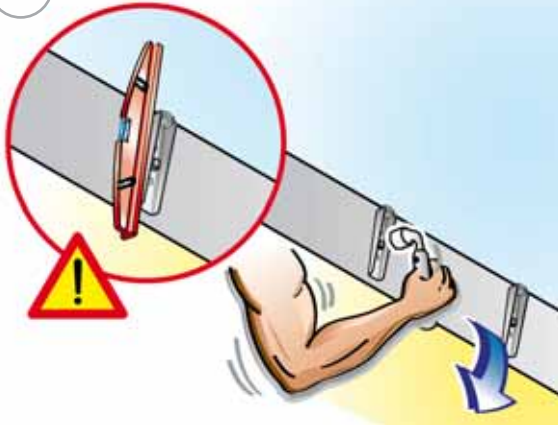

17

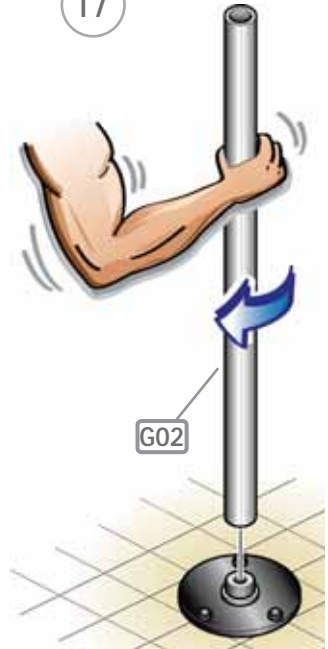

slim

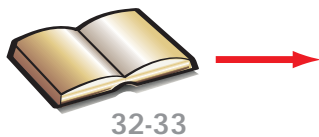
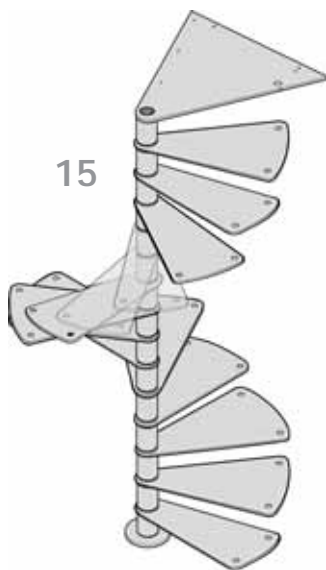
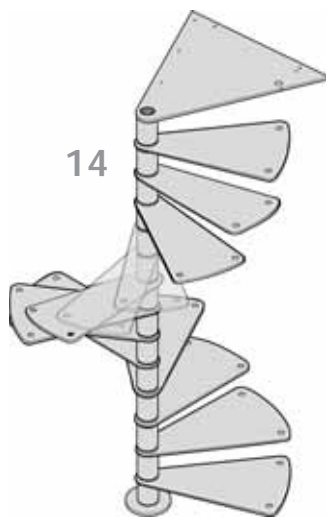
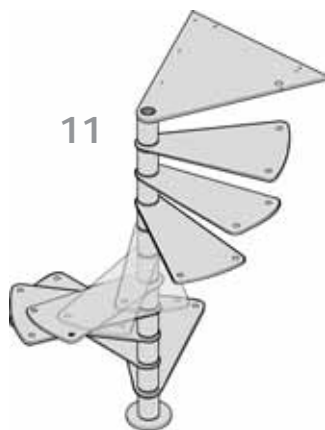
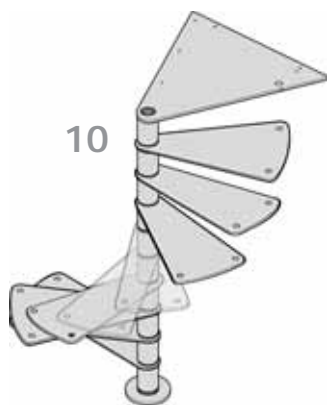

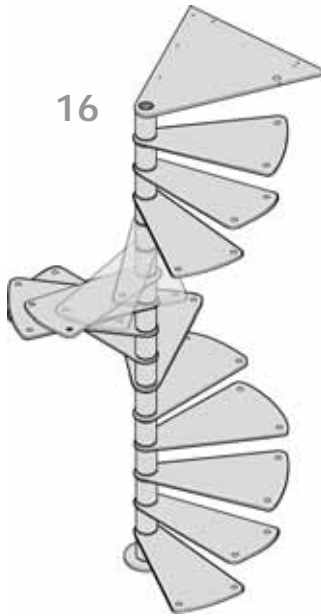
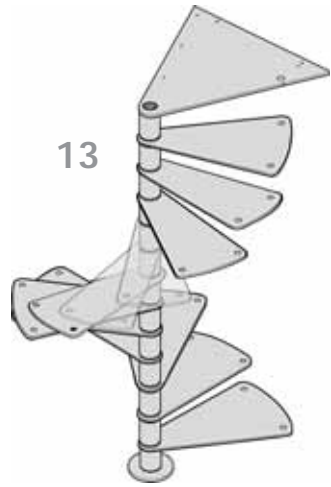
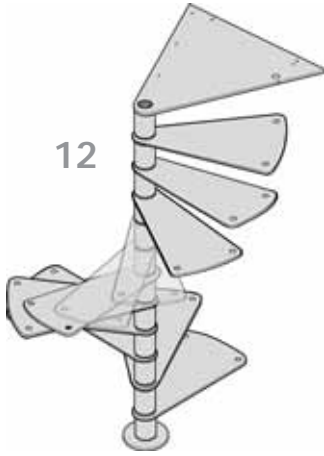

H	D47	D45
208	10	0
209	10	2
210	10	4
211	10	6
212	10	8
213	10	10
214	10	12
215	10	14
216	10	16
217	10	18
218	10	20
219	10	22
220	10	24
221	10	26
222	10	28
223	10	30
224	10	32
225	10	34
226	10	36
227	10	38
228	10	40
229	10	42
230	10	44
231	10	46
232	10	48
233	10	50
234	10	52
235	10	54
236	10	56
237	10	58
238	10	60

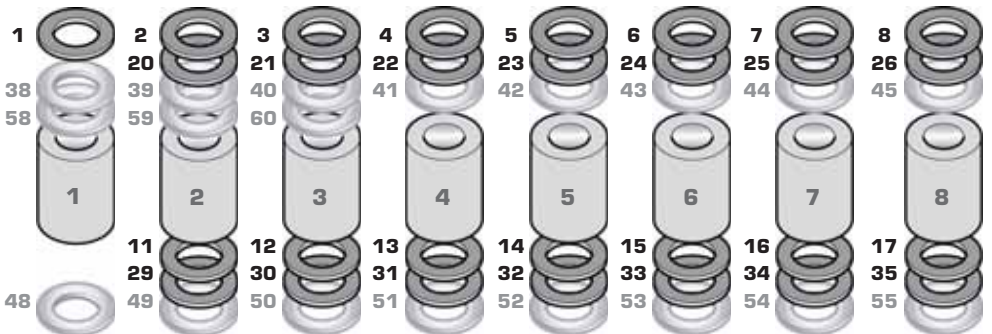
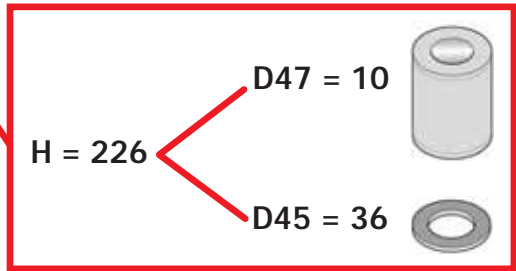
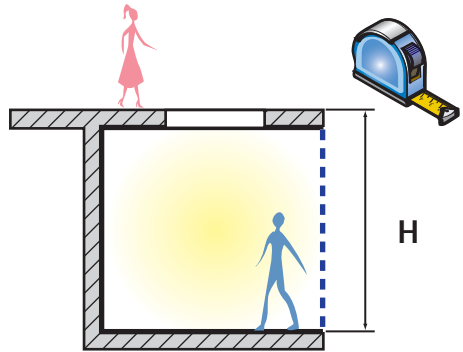

slim

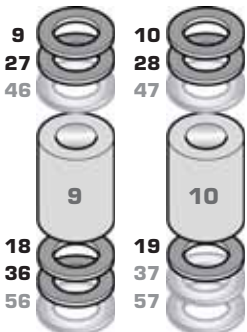
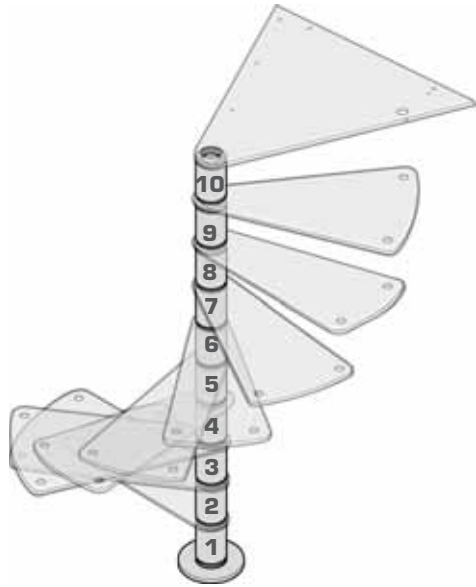
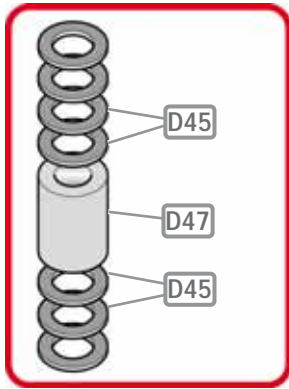

H	D47	D45
229	11	1
230	11	3
231	11	5
232	11	7
233	11	9
234	11	11
235	11	13
236	11	15
237	11	17
238	11	19
239	11	21
240	11	23
241	11	25
242	11	27
243	11	29
244	11	31
245	11	33
246	11	35
247	11	37
248	11	39
249	11	41
250	11	43
251	11	45
252	11	47
253	11	49
254	11	51
255	11	53
256	11	55
257	11	57
258	11	59
259	11	61
260	11	63
261	11	65

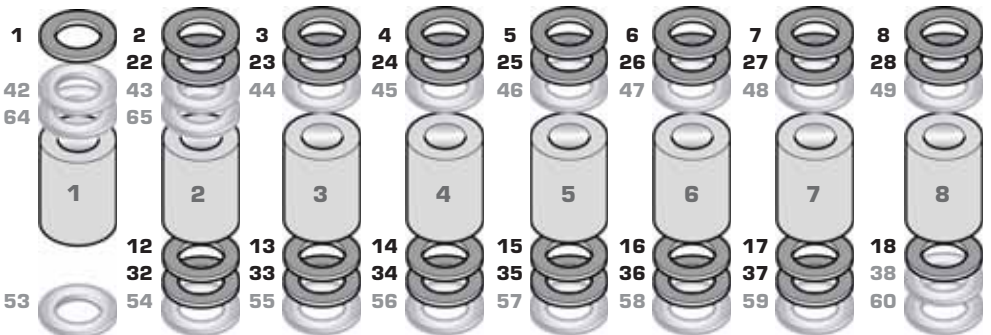
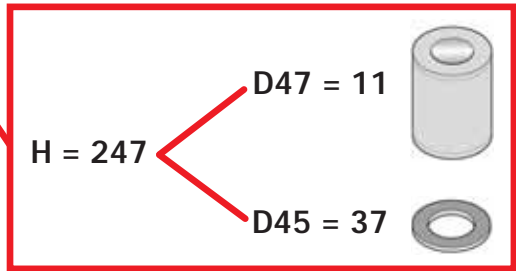
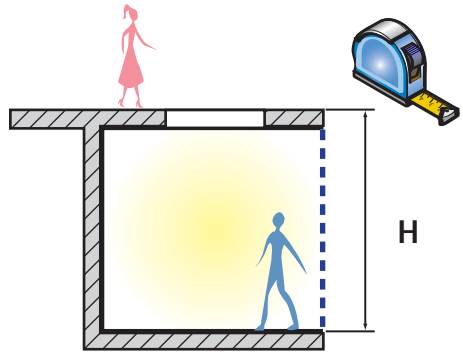

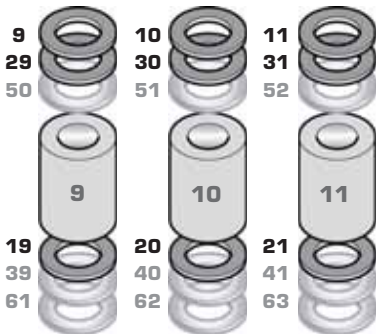
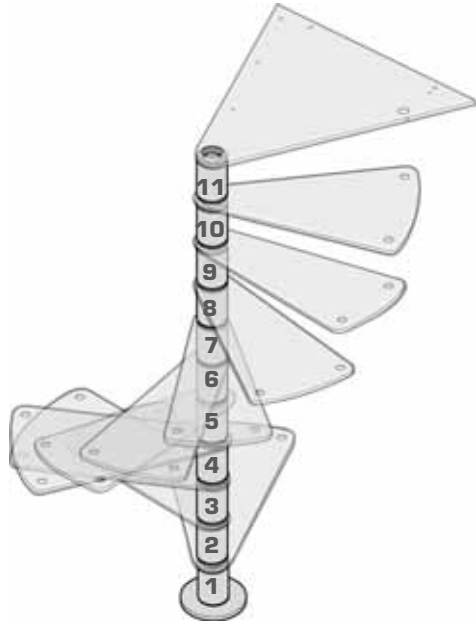
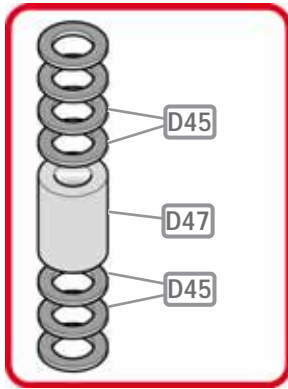

H	D47	D45
250	12	2
251	12	4
252	12	6
253	12	8
254	12	10
255	12	12
256	12	14
257	12	16
258	12	18
259	12	20
260	12	22
261	12	24
262	12	26
263	12	28
264	12	30
265	12	32
266	12	34
267	12	36
268	12	38
269	12	40
270	12	42
271	12	44
272	12	46
273	12	48
274	12	50
275	12	52
276	12	54
277	12	56
278	12	58
279	12	60
280	12	62
281	12	64
282	12	66
283	12	68
284	12	70
285	12	72

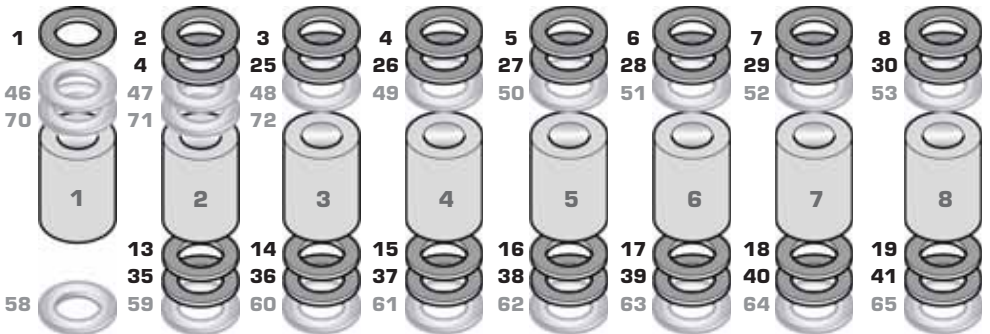
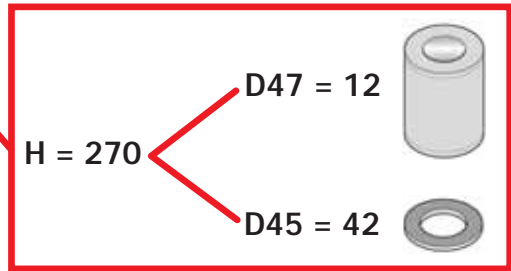
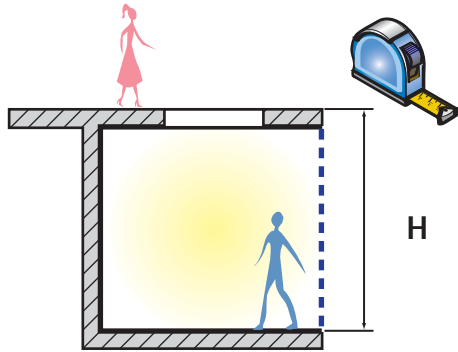

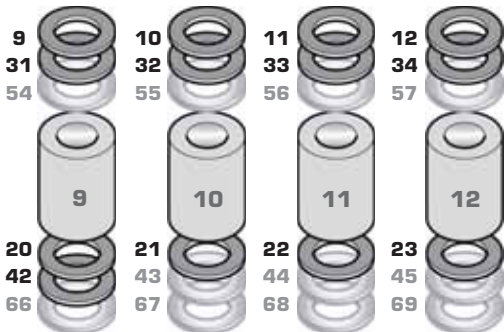
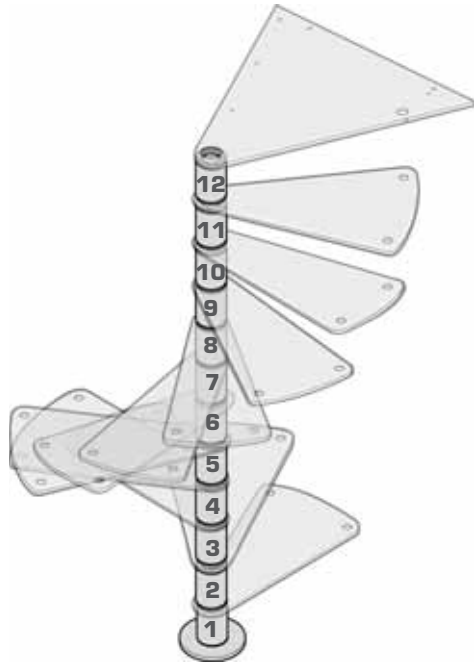
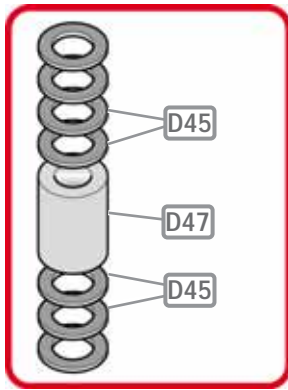

H	D47	D45
271	13	2
272	13	4
273	13	6
274	13	8
275	13	10
276	13	12
277	13	14
278	13	16
279	13	18
280	13	20
281	13	22
282	13	24
283	13	26
284	13	28
285	13	30
286	13	32
287	13	34
288	13	36
289	13	38
290	13	40
291	13	42
292	13	44
293	13	46
294	13	48
295	13	50
296	13	52
297	13	54
298	13	56
299	13	58
300	13	60
301	13	62
302	13	64
303	13	66
304	13	68
305	13	70
306	13	72
307	13	74
308	13	76
309	13	78

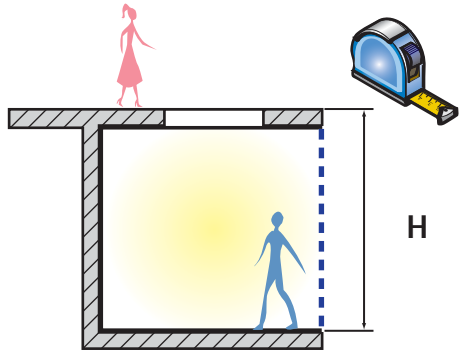

H = 292

D47 = 13

D45 = 44

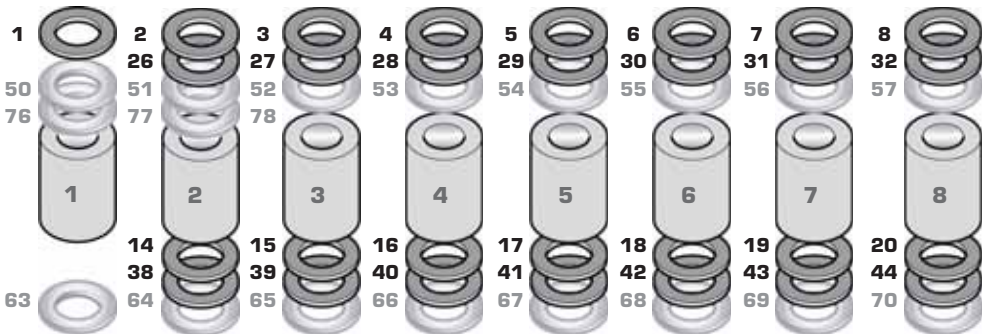

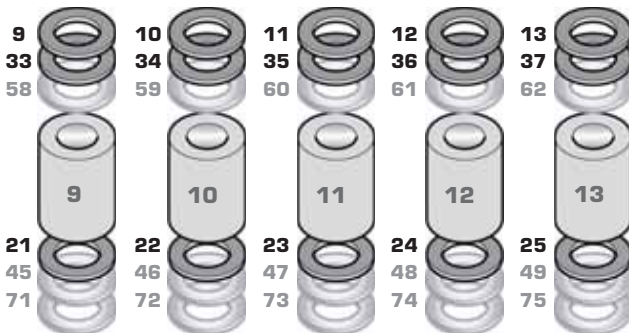
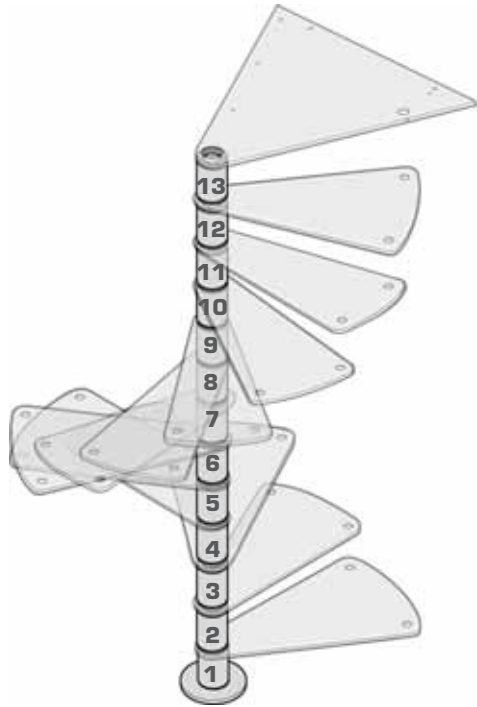
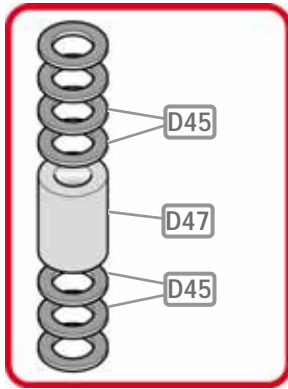

H	D47	D45
291	14	1
292	14	3
293	14	5
294	14	7
295	14	9
296	14	11
297	14	13
298	14	15
299	14	17
300	14	19
301	14	21
302	14	23
303	14	25
304	14	27
305	14	29
306	14	31
307	14	33
308	14	35
309	14	37
310	14	39
311	14	41
312	14	43
313	14	45
314	14	47
315	14	49
316	14	51
317	14	53
318	14	55
319	14	57
320	14	59
321	14	61
322	14	63
323	14	65
324	14	67
325	14	69
326	14	71
327	14	73
328	14	75
329	14	77
330	14	79
331	14	81
332	14	83

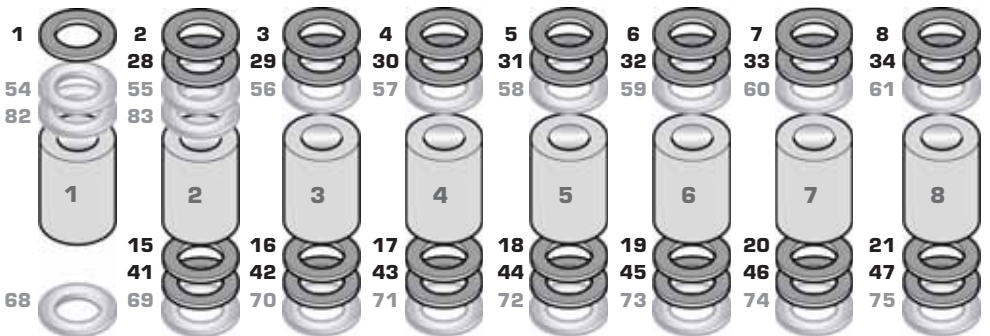
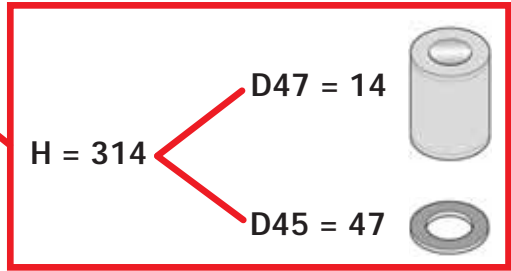
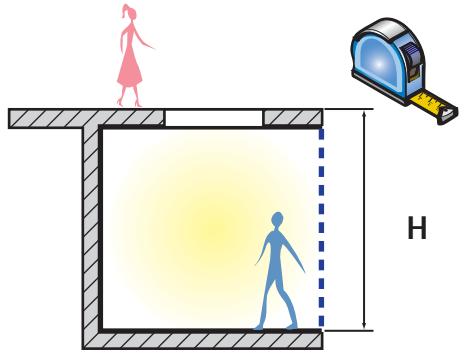

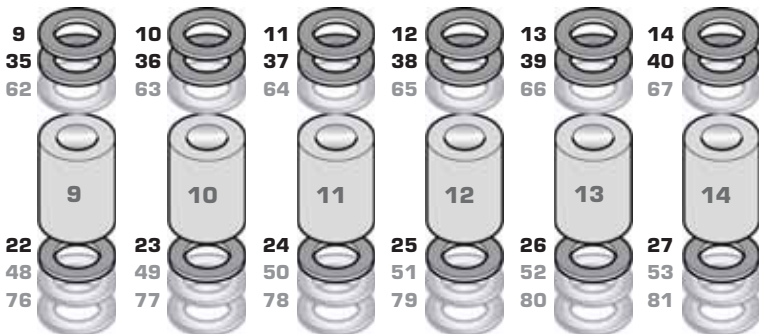
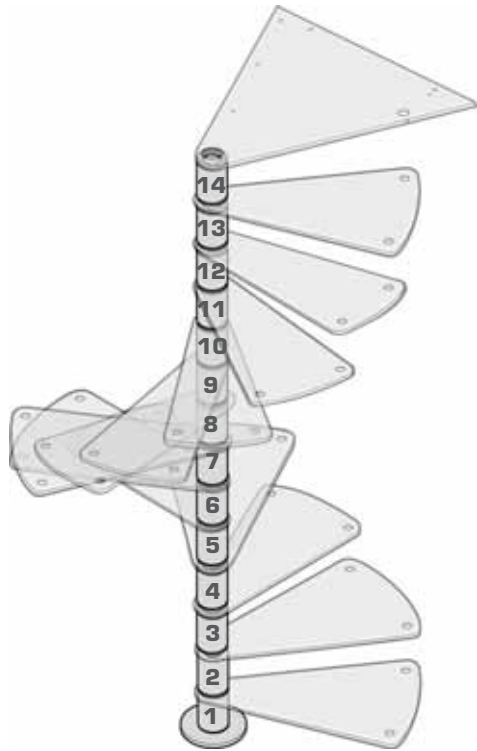
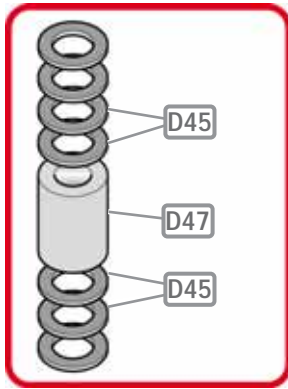

H	D47	D45
312	15	1
313	15	3
314	15	5
315	15	7
316	15	9
317	15	11
318	15	13
319	15	15
320	15	17
321	15	19
322	15	21
323	15	23
324	15	25
325	15	27
326	15	29
327	15	31
328	15	33
329	15	35
330	15	37
331	15	39
332	15	41
333	15	43
334	15	45
335	15	47
336	15	49
337	15	51
338	15	53
339	15	55
340	15	57
341	15	59
342	15	61
343	15	63
344	15	65
345	15	67
346	15	69
347	15	71
348	15	73
349	15	75
350	15	77
351	15	79
352	15	81
353	15	83
354	15	85
355	15	87
356	15	89

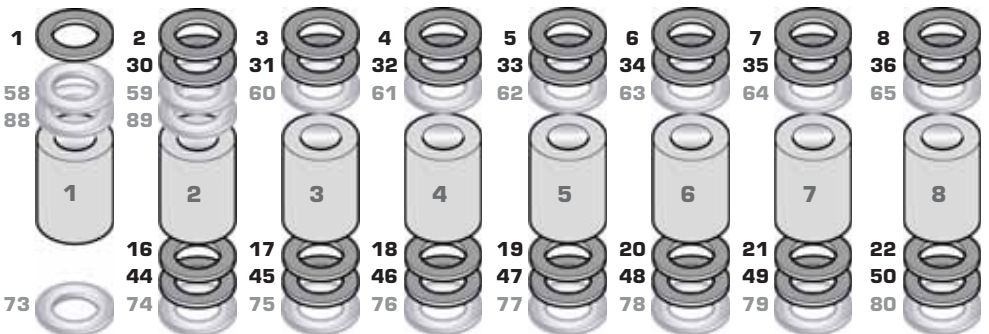
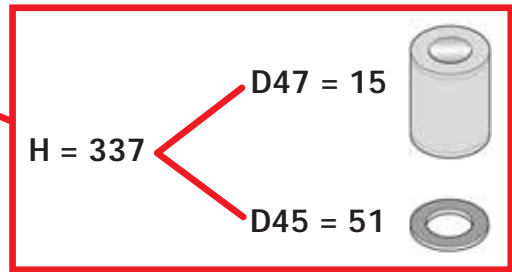
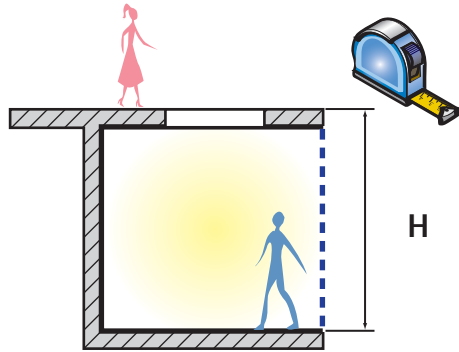

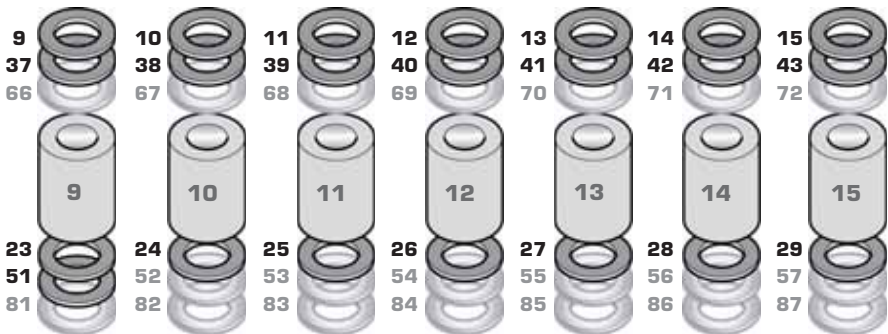
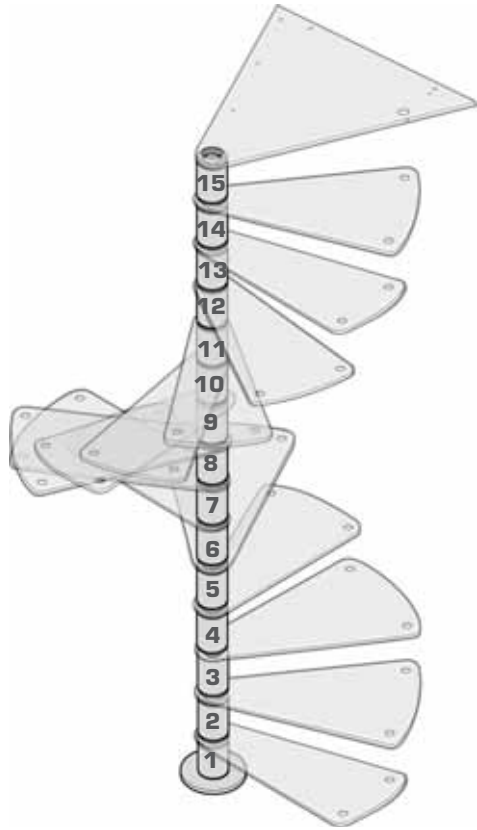
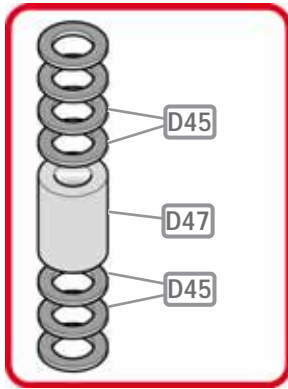

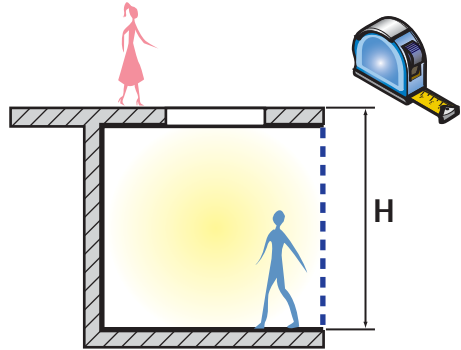

H	D47	D45
333	16	2
334	16	4
335	16	6
336	16	8
337	16	10
338	16	12
339	16	14
340	16	16
341	16	18
342	16	20
343	16	22
344	16	24
345	16	26
346	16	28
347	16	30
348	16	32
349	16	34
350	16	36
351	16	38
352	16	40
353	16	42
354	16	44
355	16	46
356	16	48
357	16	50
358	16	52
359	16	54
360	16	56
361	16	58
362	16	60
363	16	62
364	16	64
365	16	66
366	16	68
367	16	70
368	16	72
369	16	74
370	16	76
371	16	78
372	16	80
373	16	82
374	16	84
375	16	86
376	16	88
377	16	90

H	D47	D45
378	16	92
379	16	94
380	16	96



H = 360

D47 = 16 

D45 = 56 

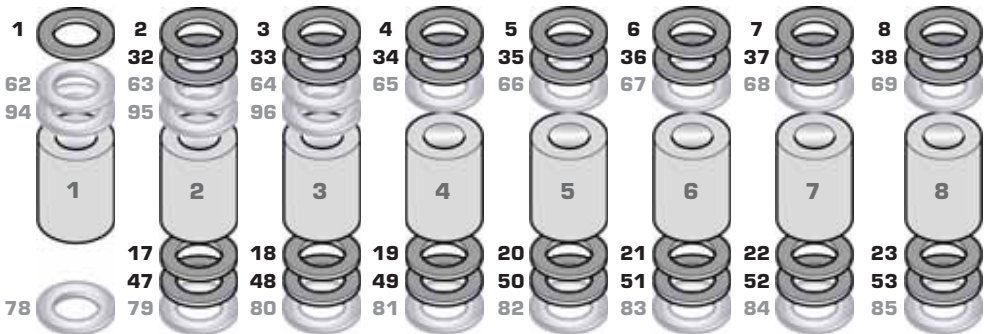

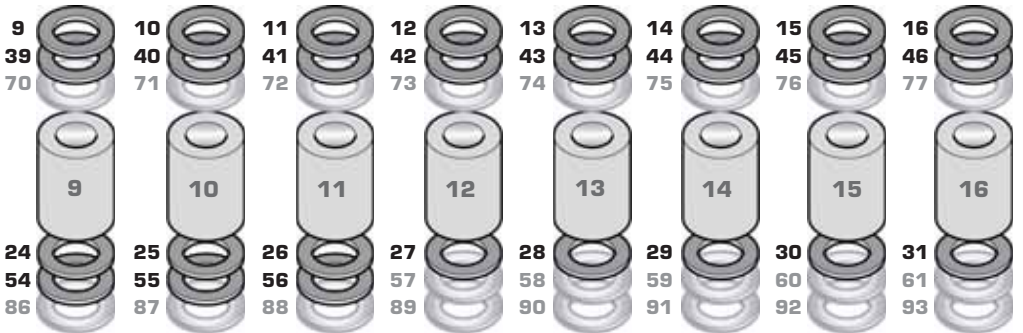
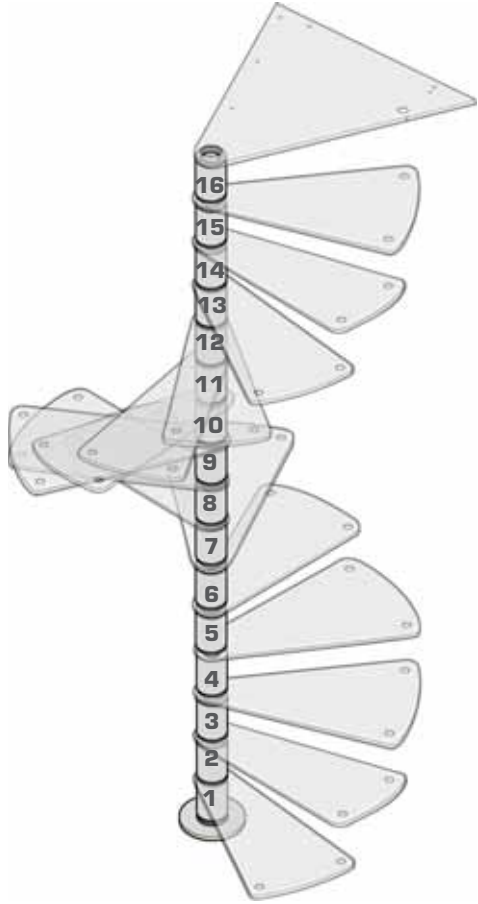
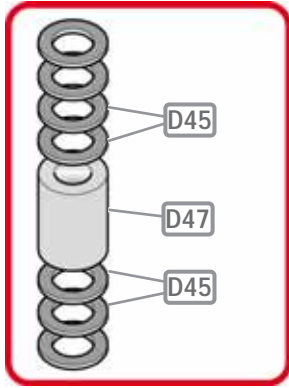

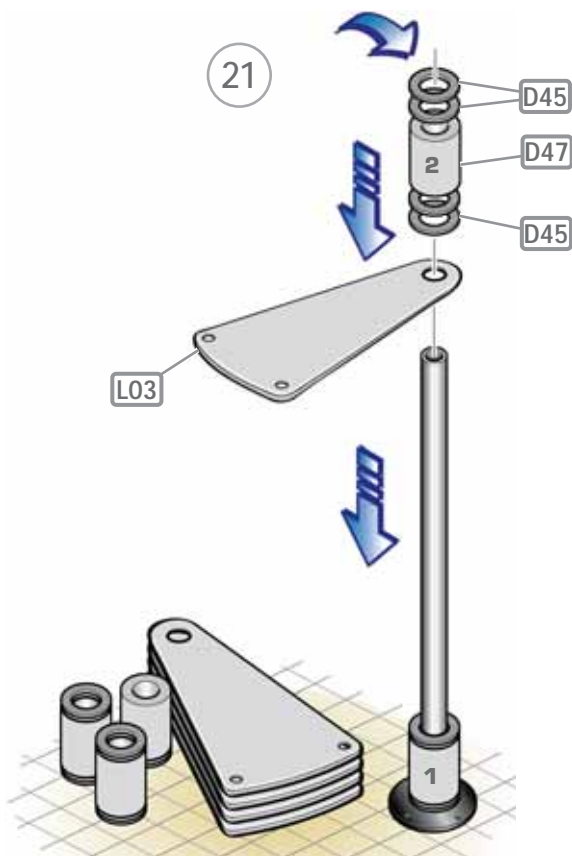
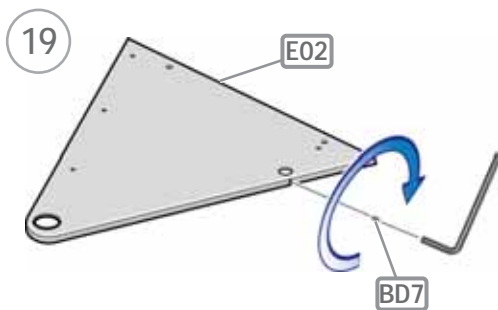
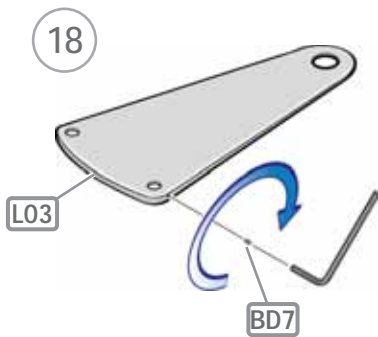

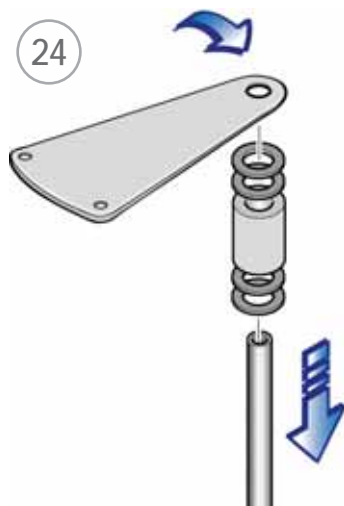
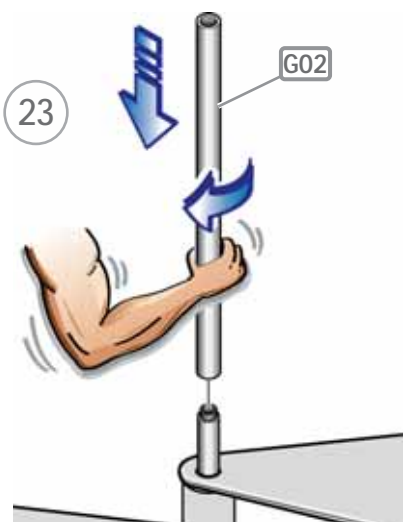
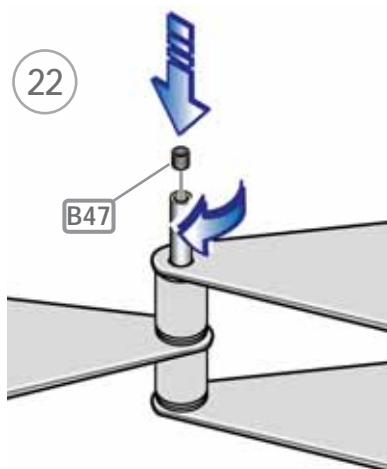

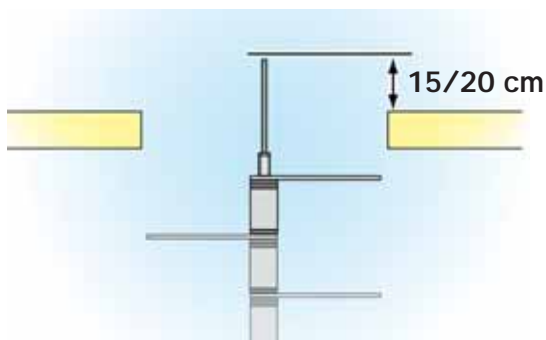
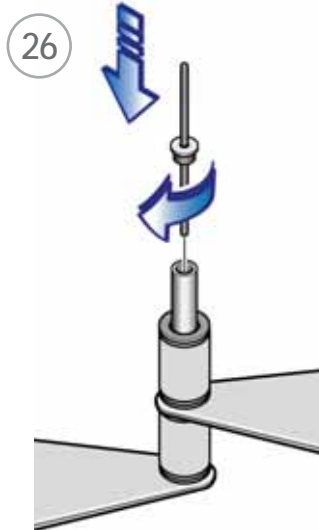
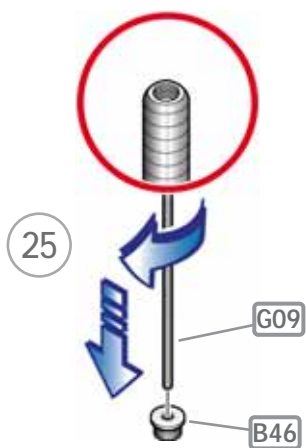

27

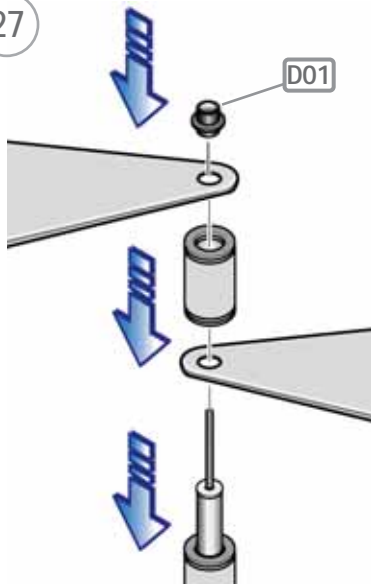

28

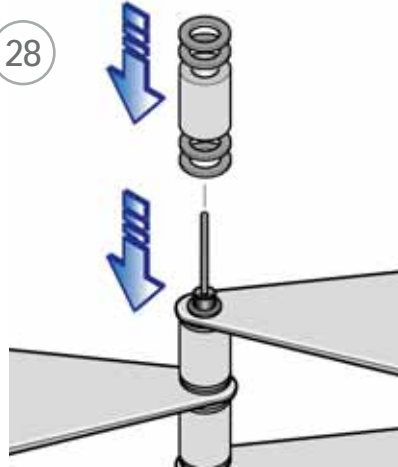

29

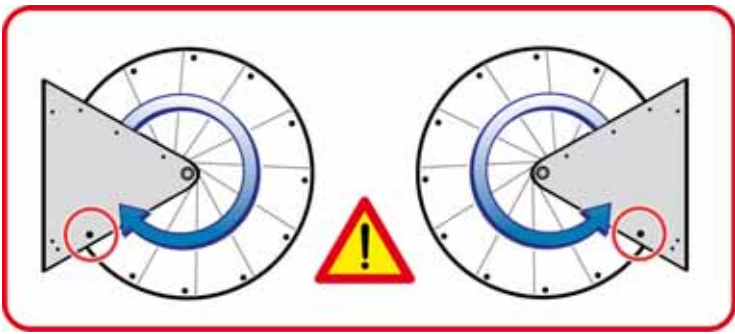
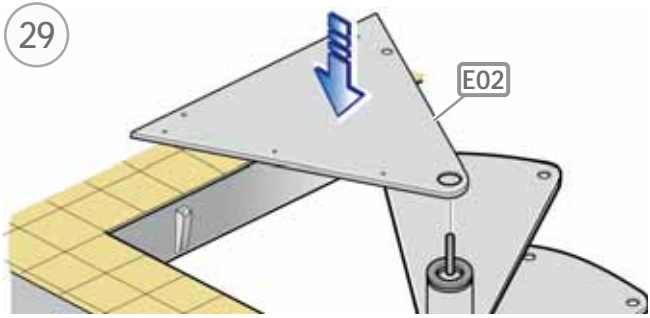

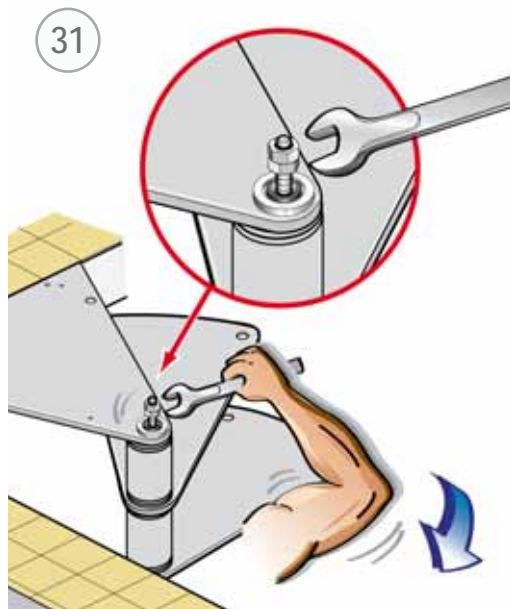
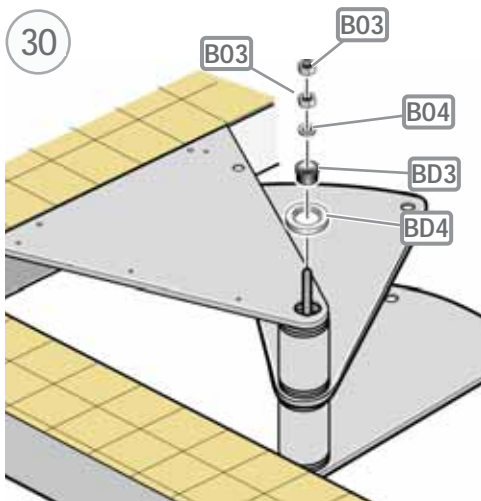

32

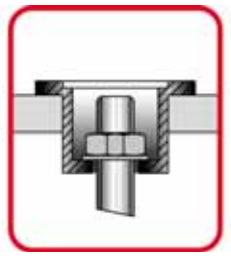
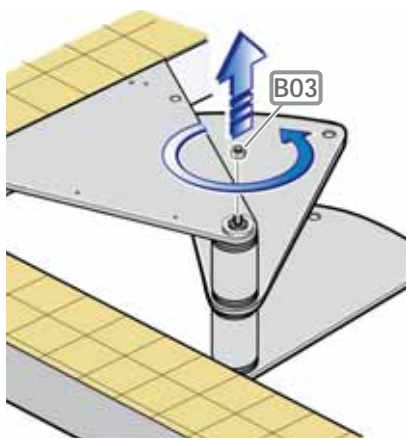

33

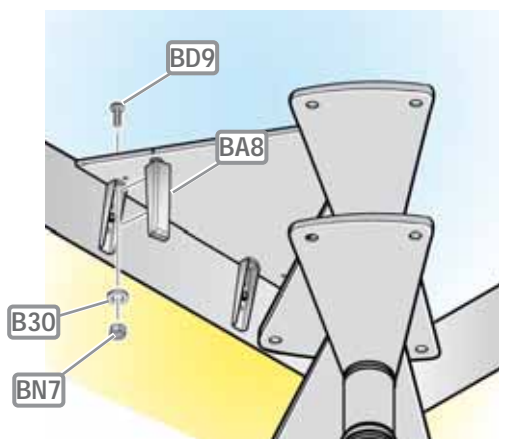

34

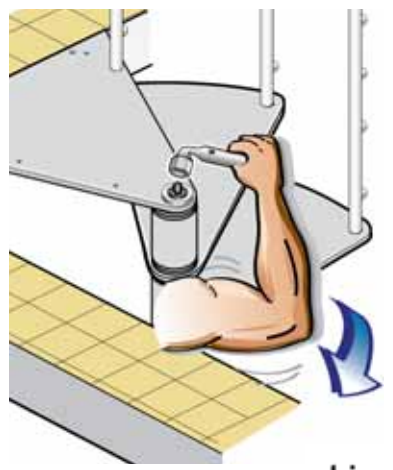

slim

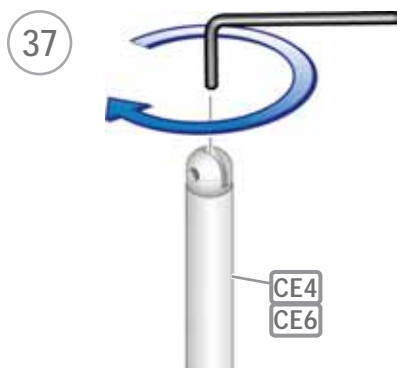
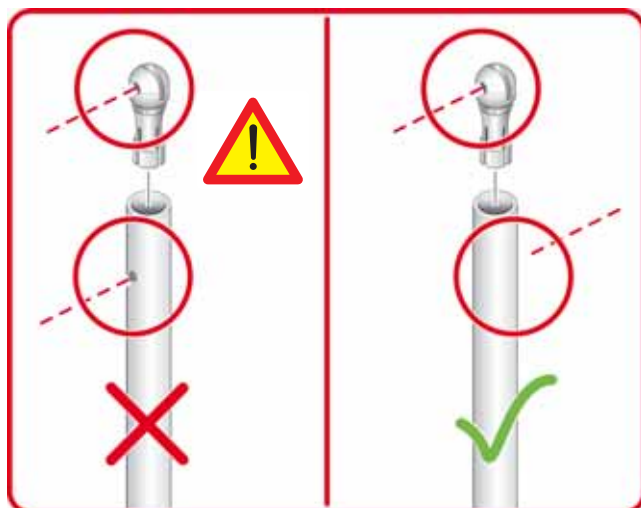
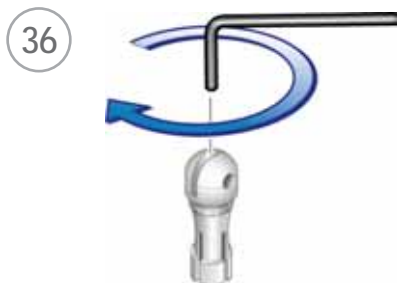
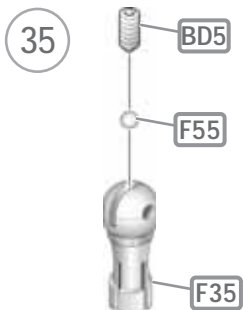

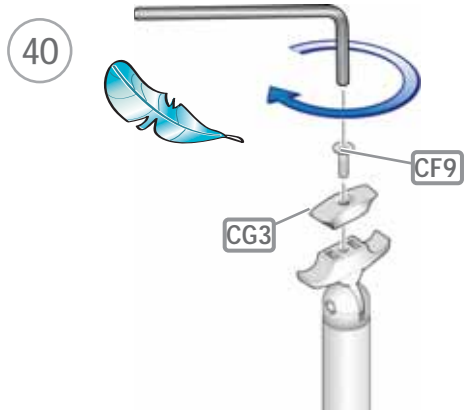
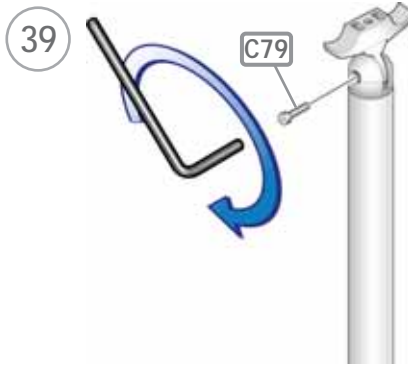
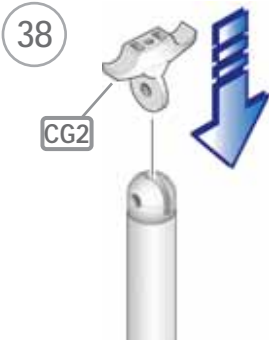

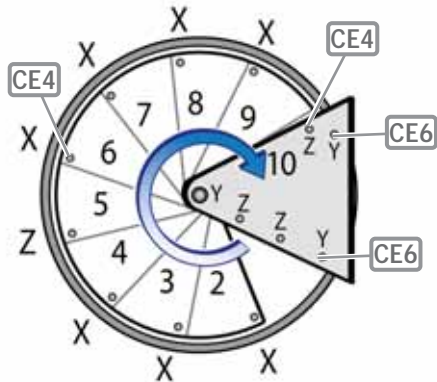
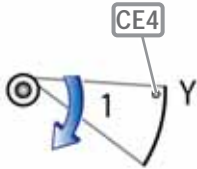
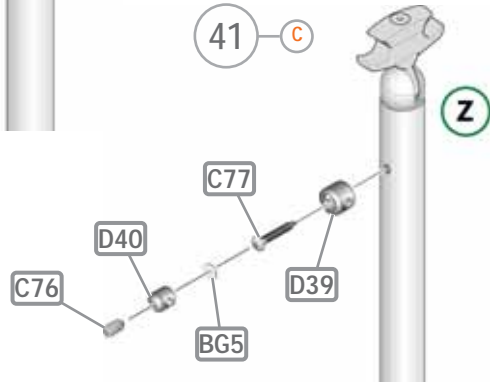
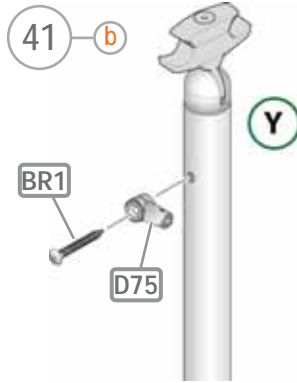
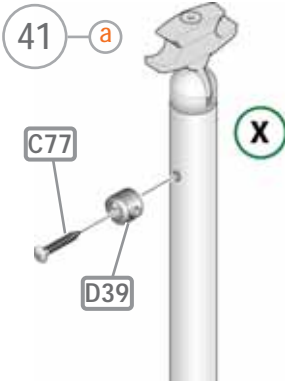

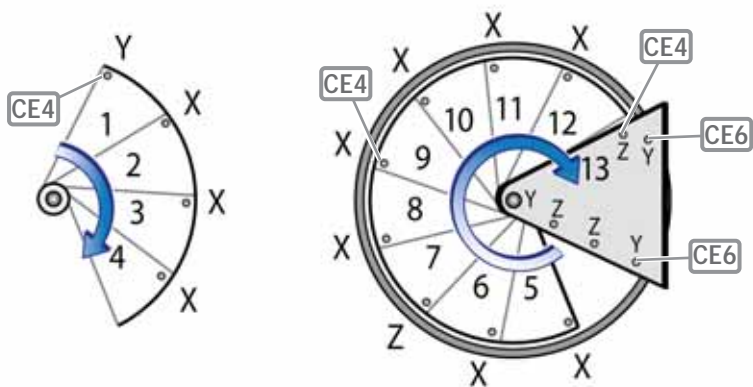
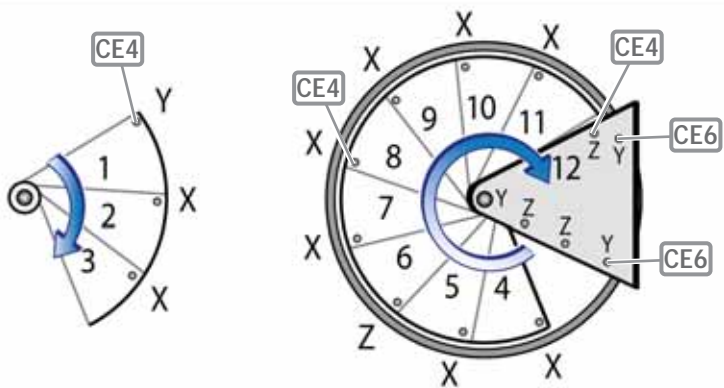
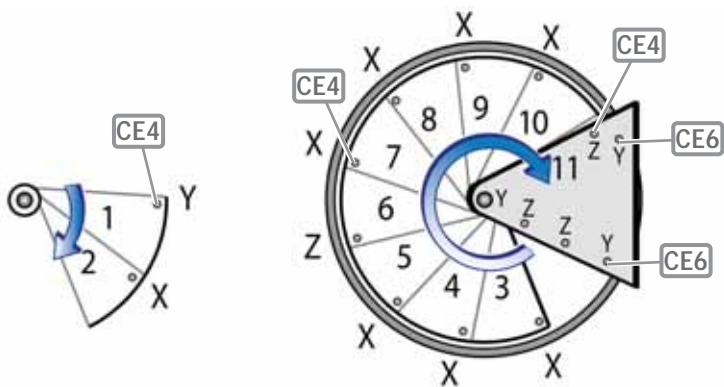

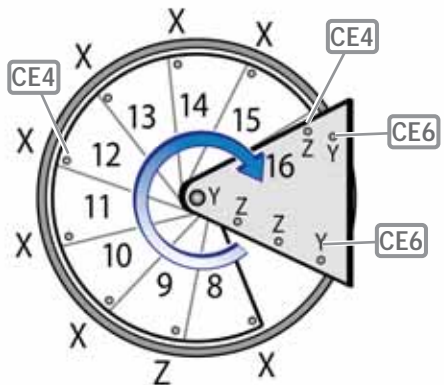
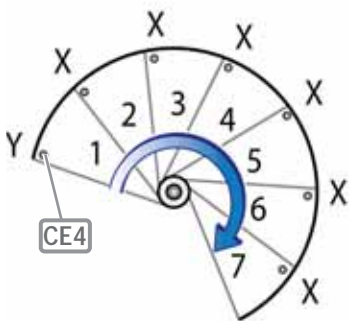
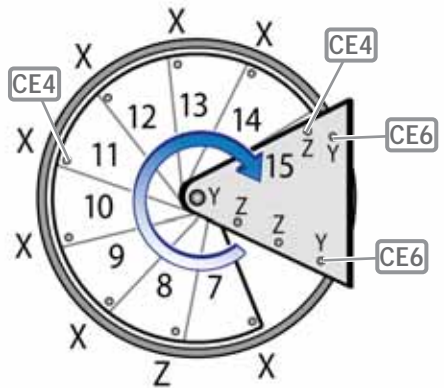
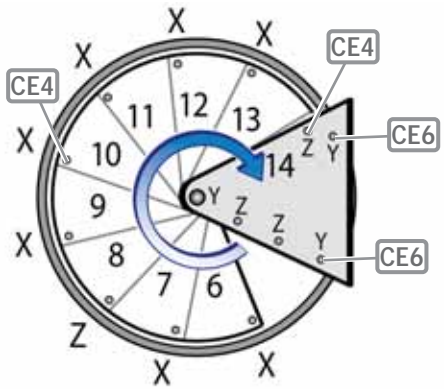
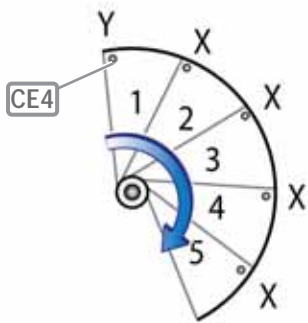

42

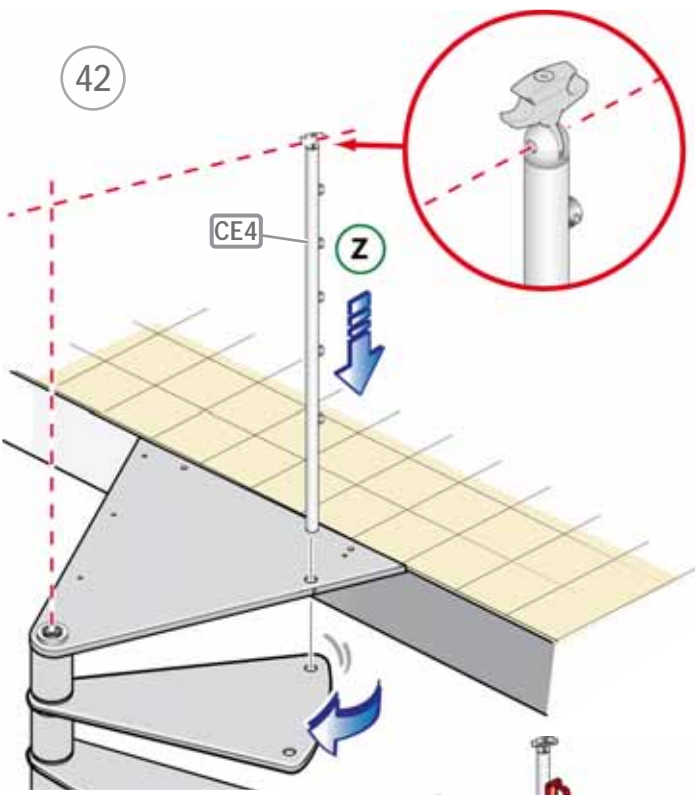

CE4

Z

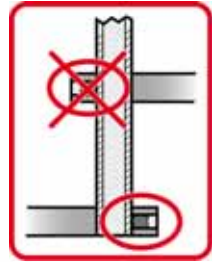

43

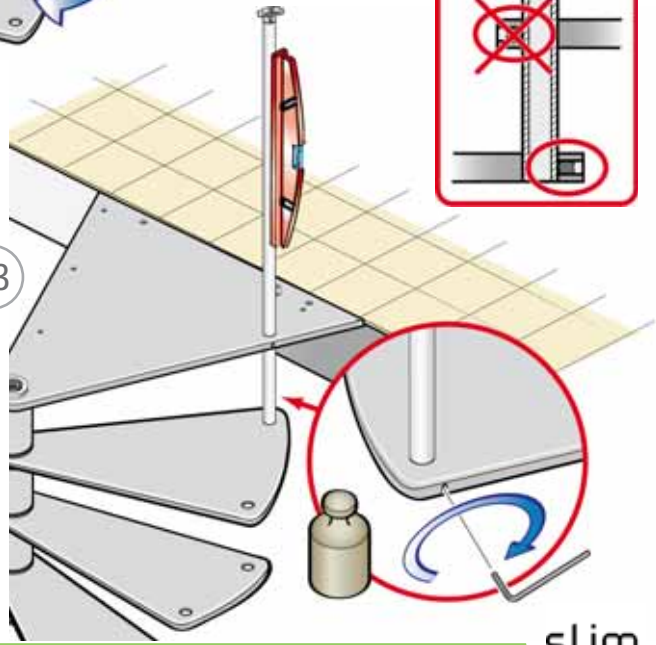

slim

44

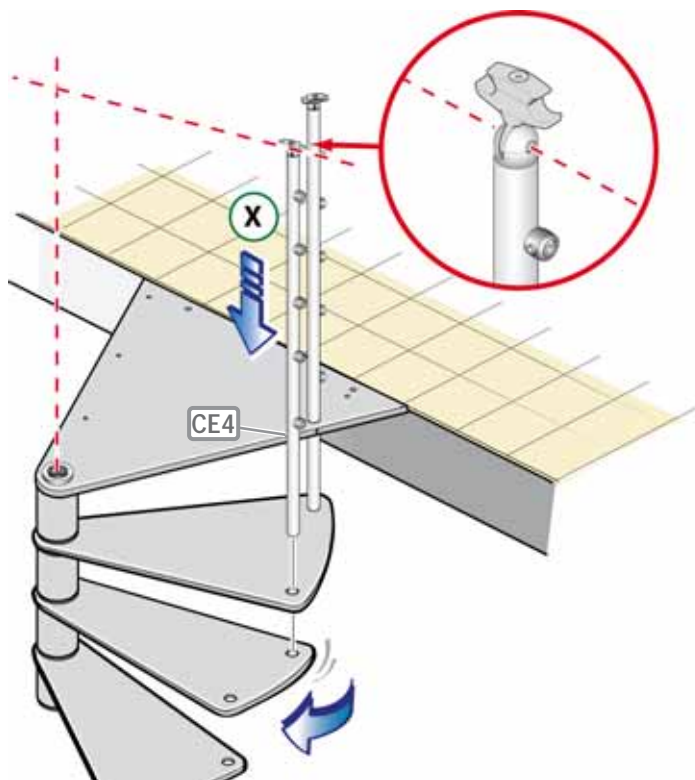

45

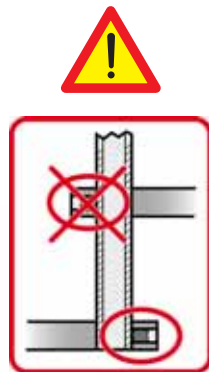
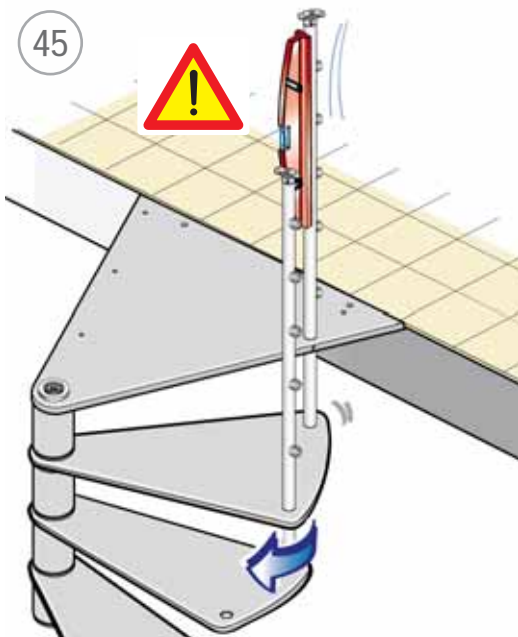

46

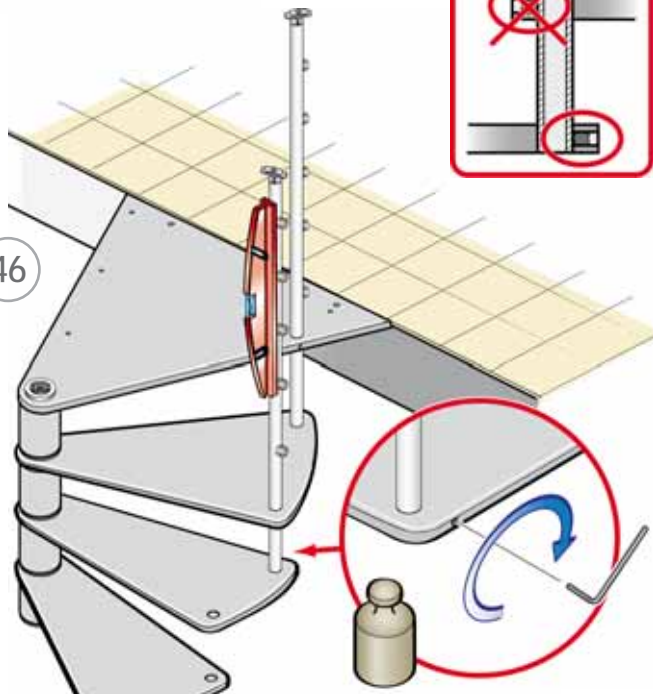
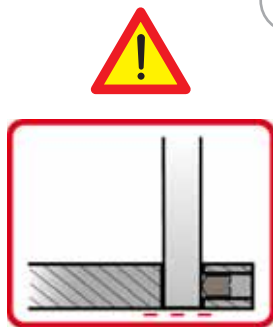

slim

47

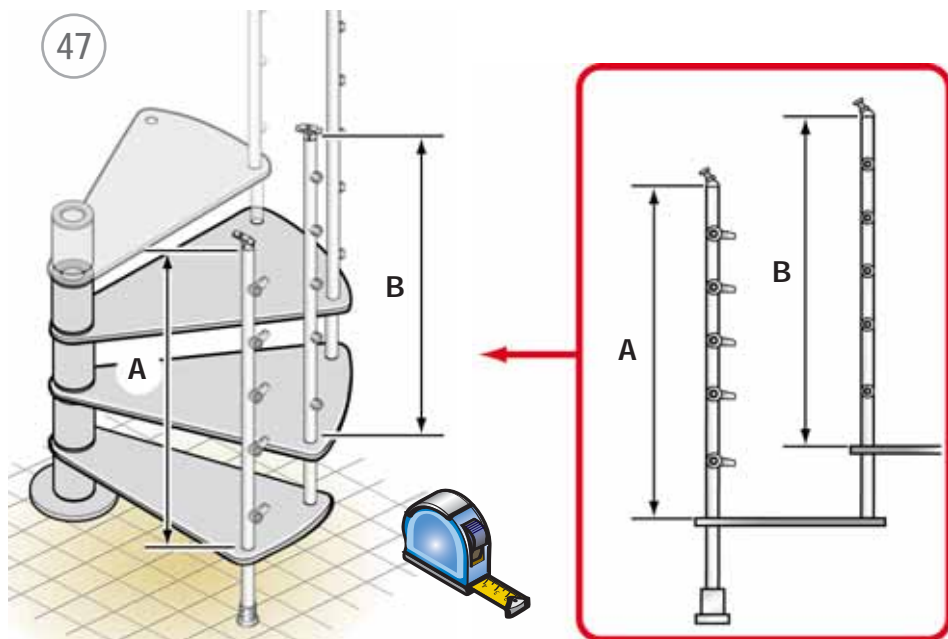

48

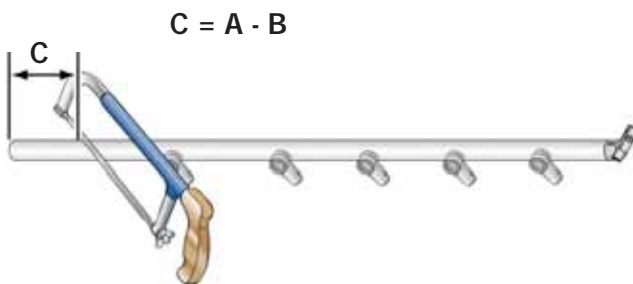

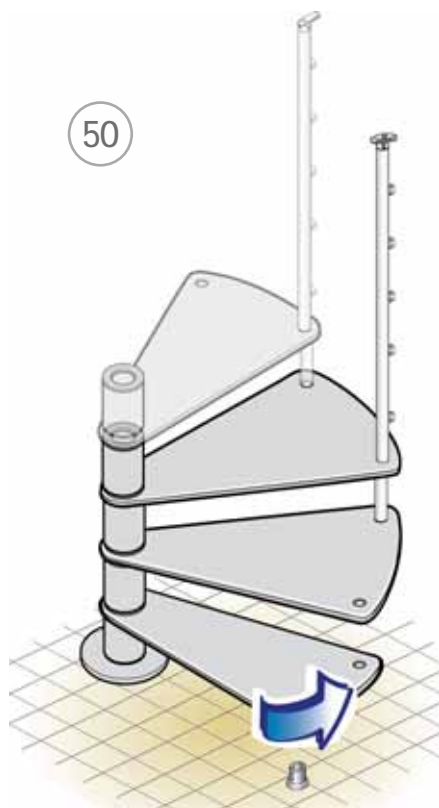
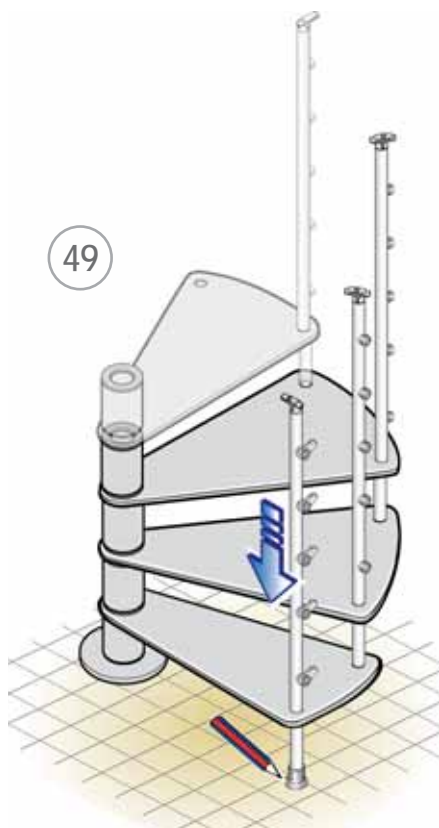

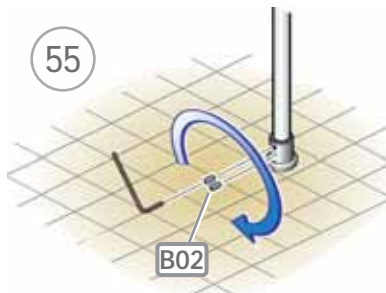
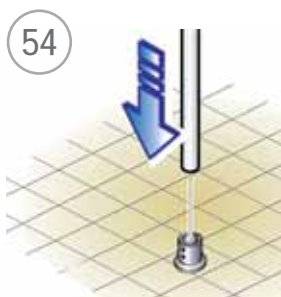
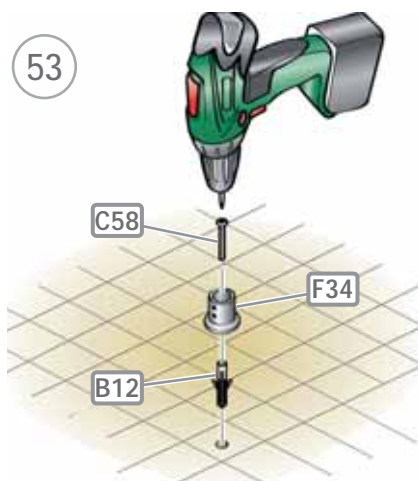
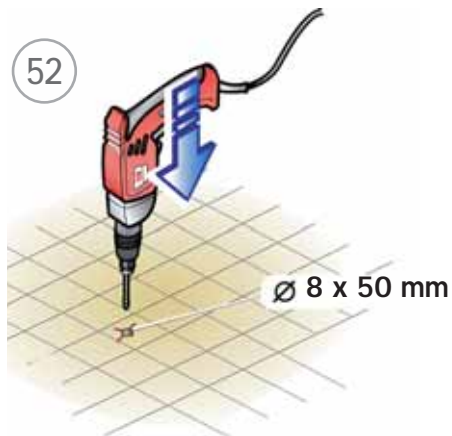
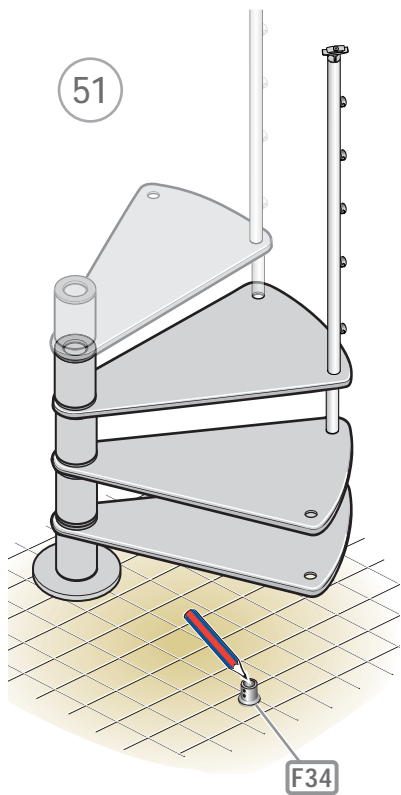

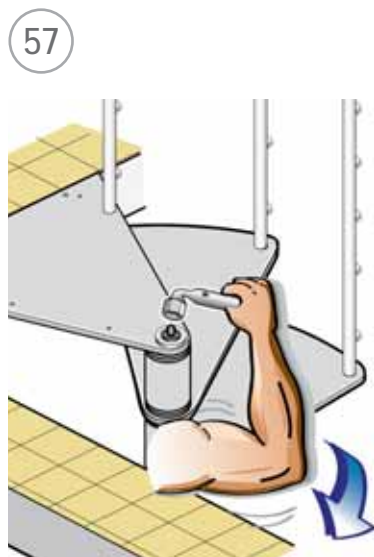
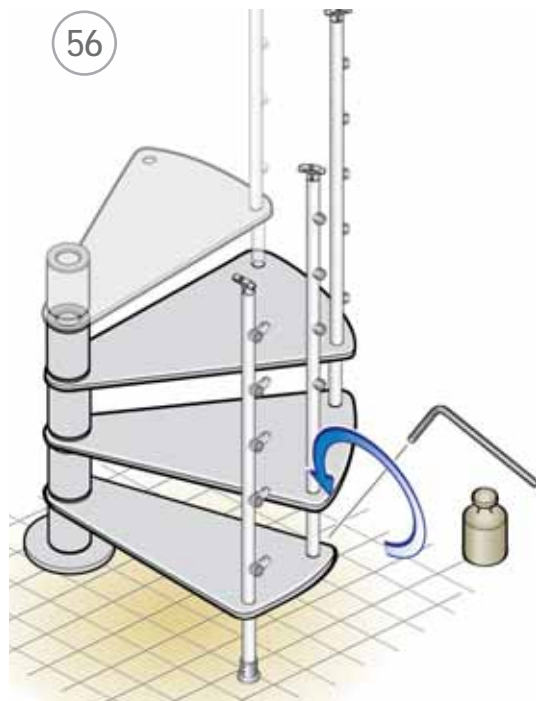

58

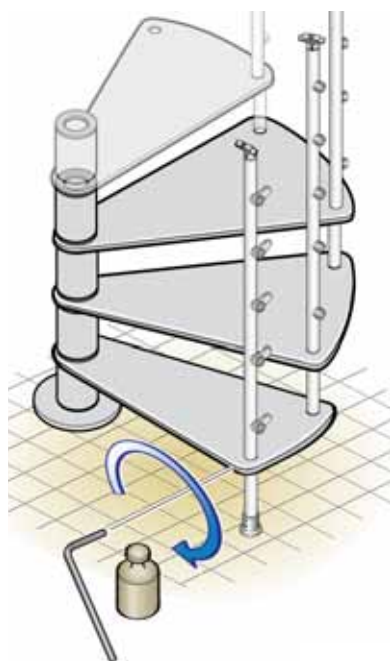
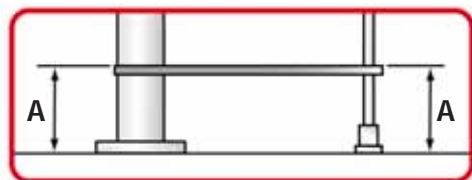

slim

59

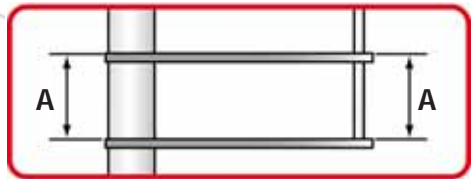
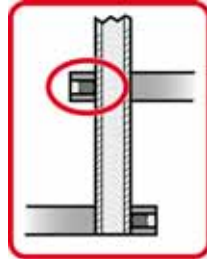
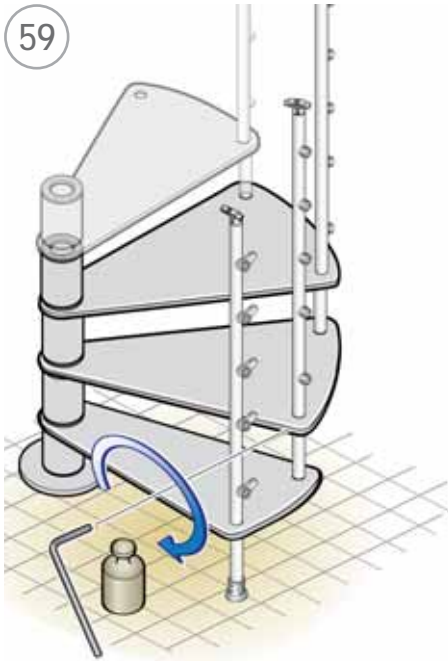

60

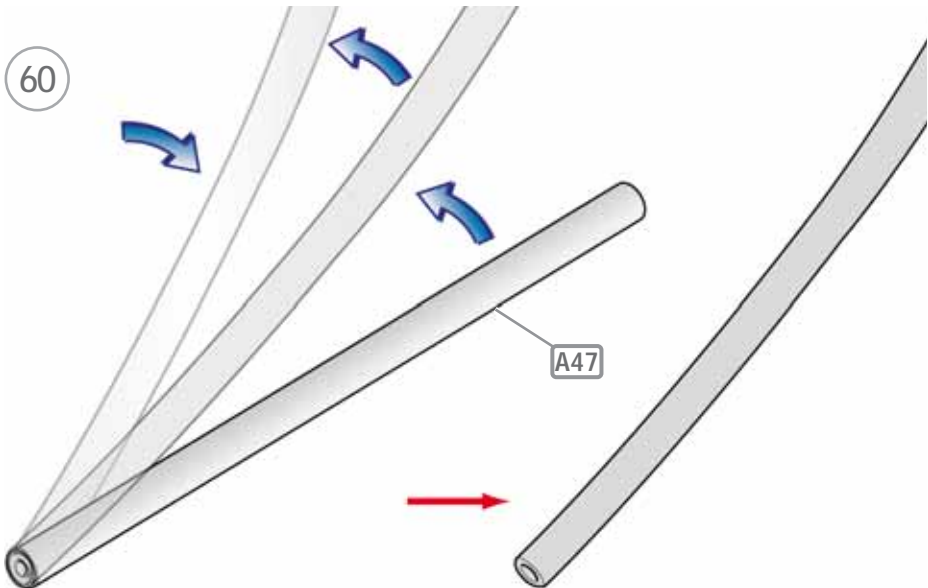

slim

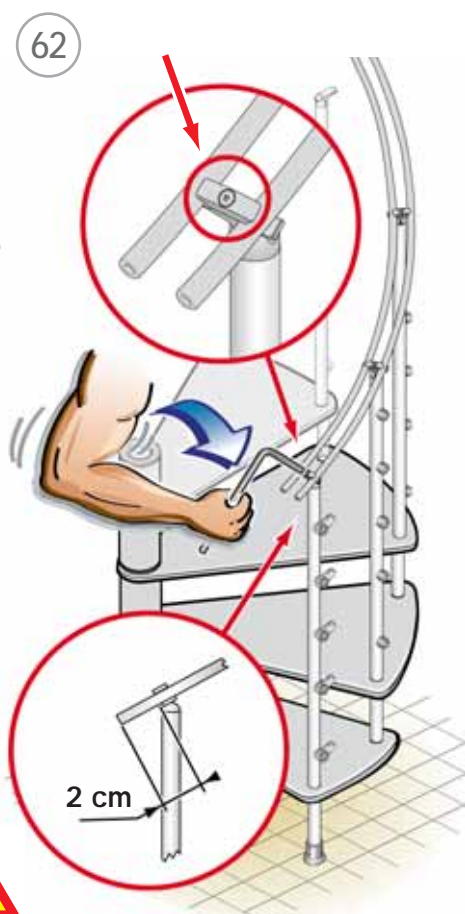
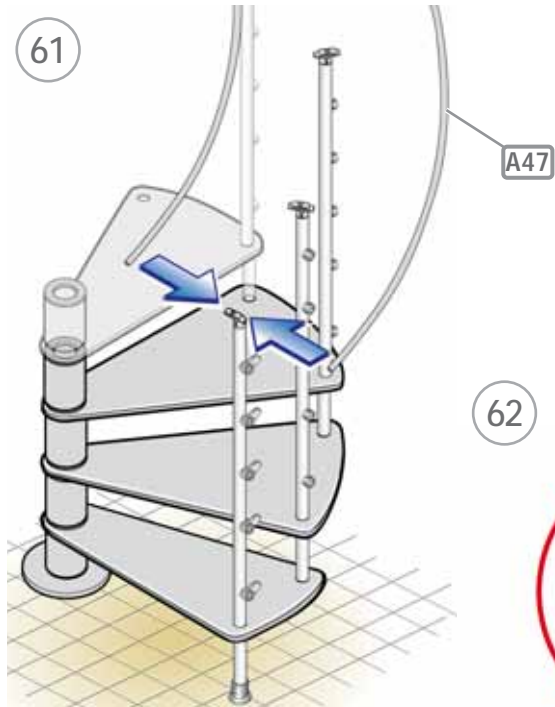

63

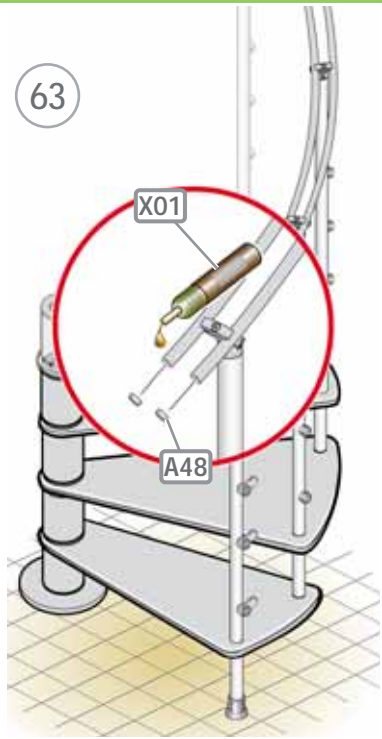

64

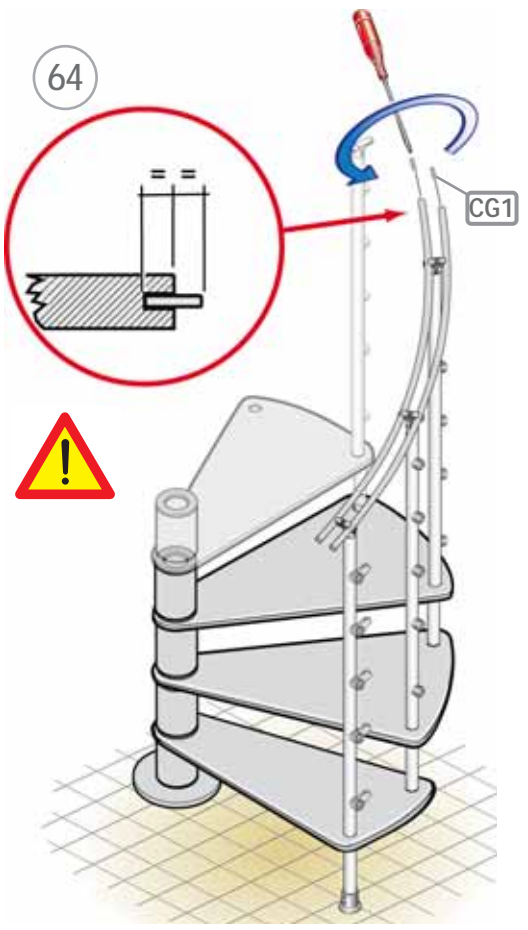

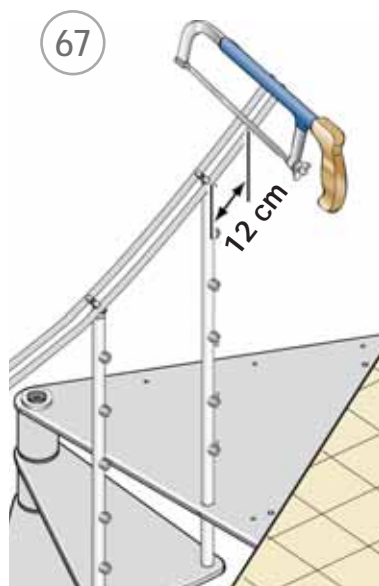
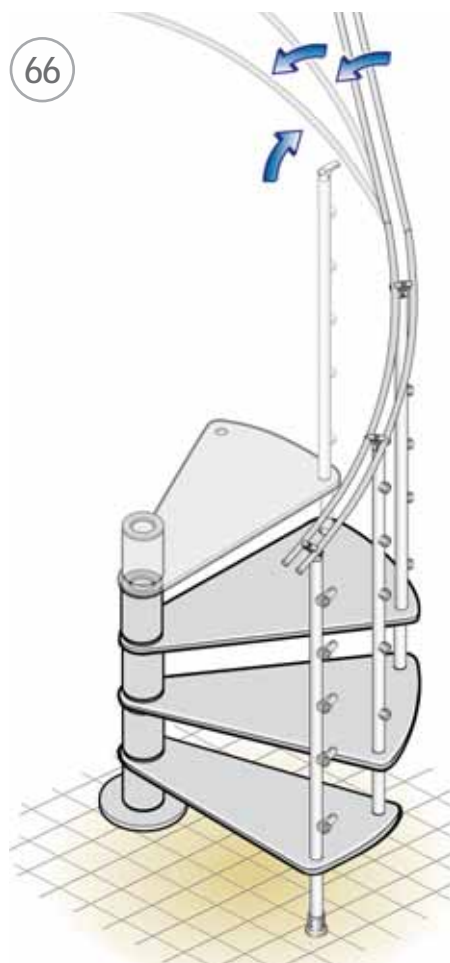
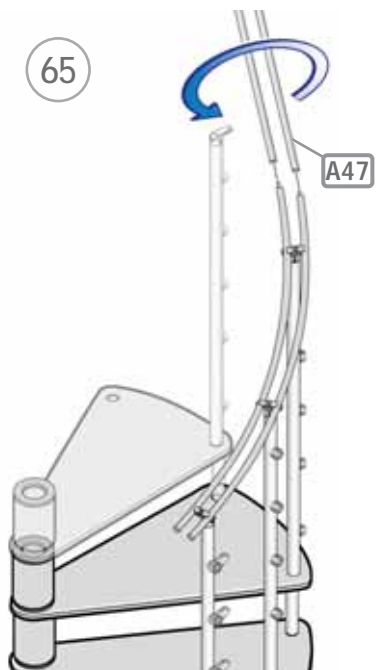

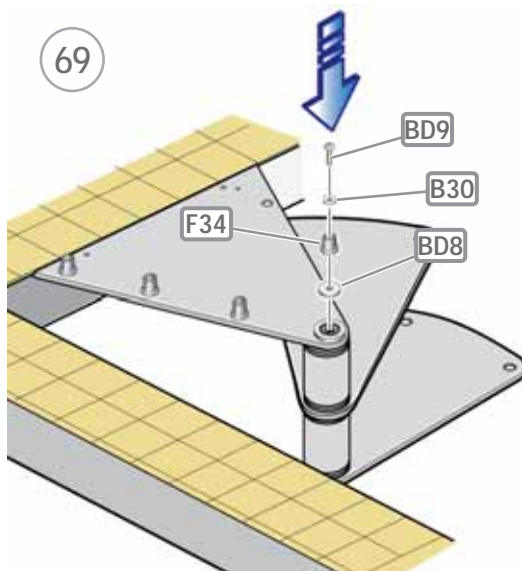
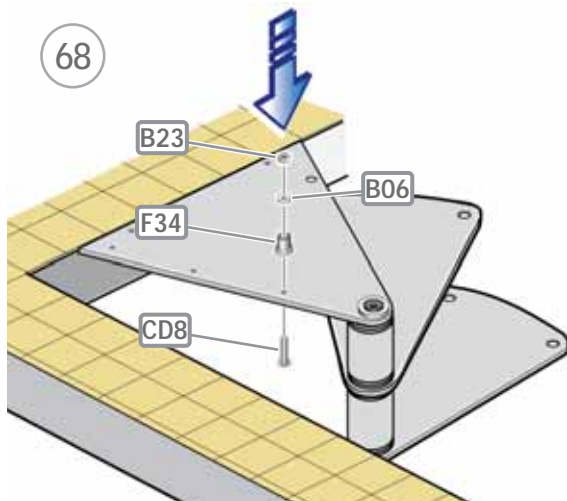

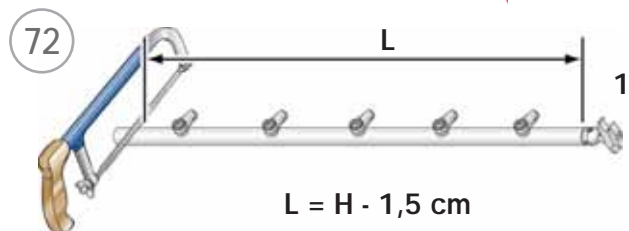
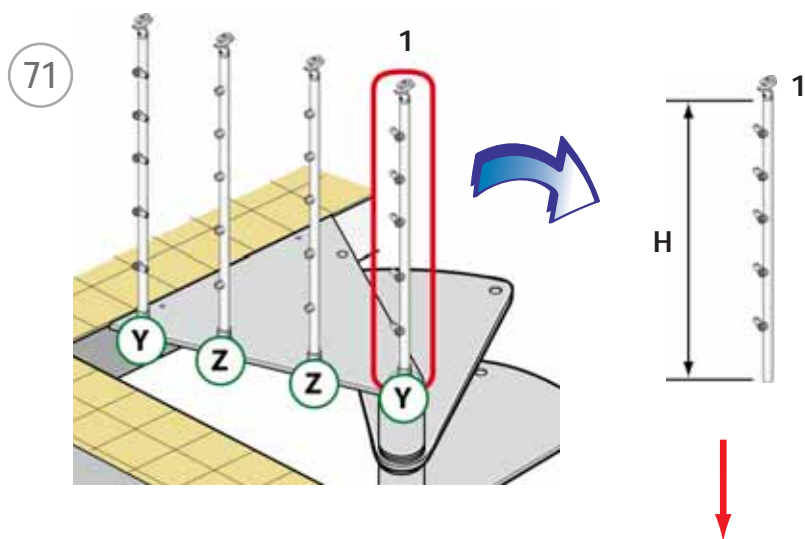
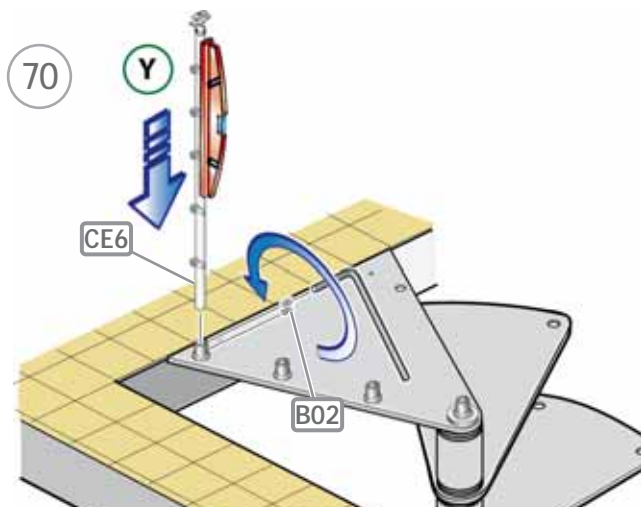

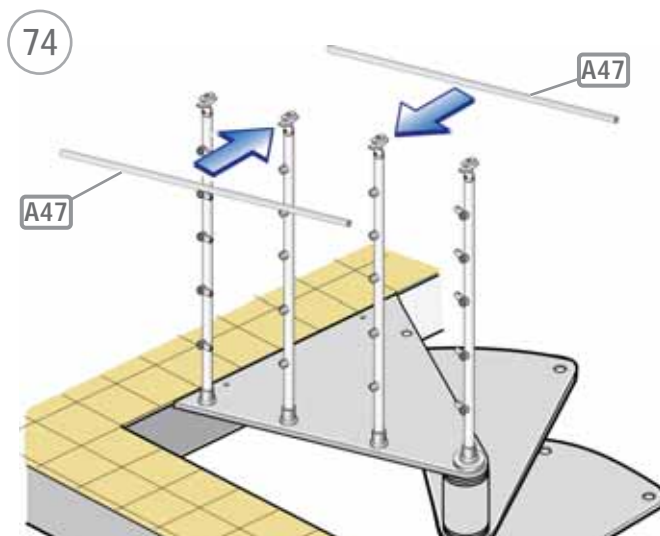
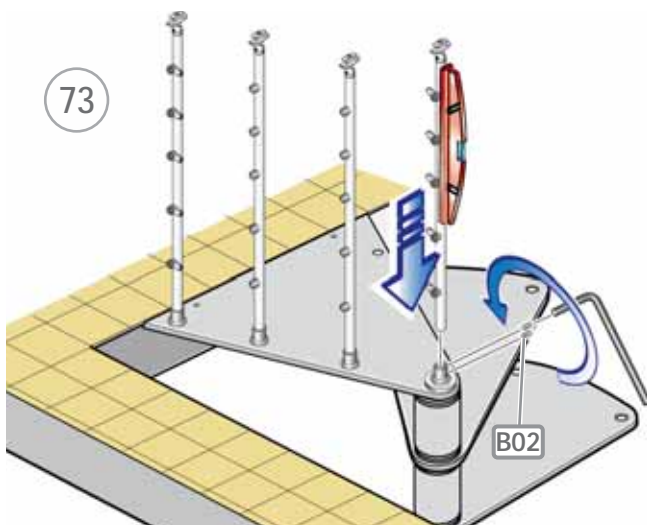

75

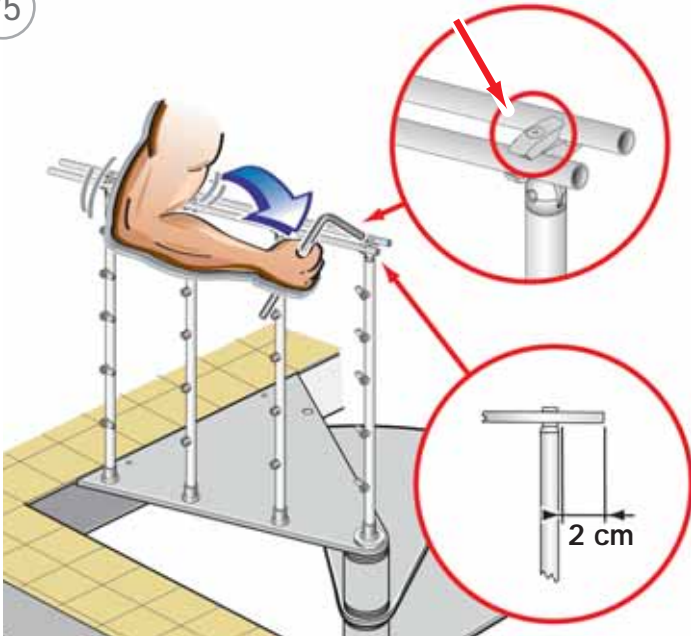

76

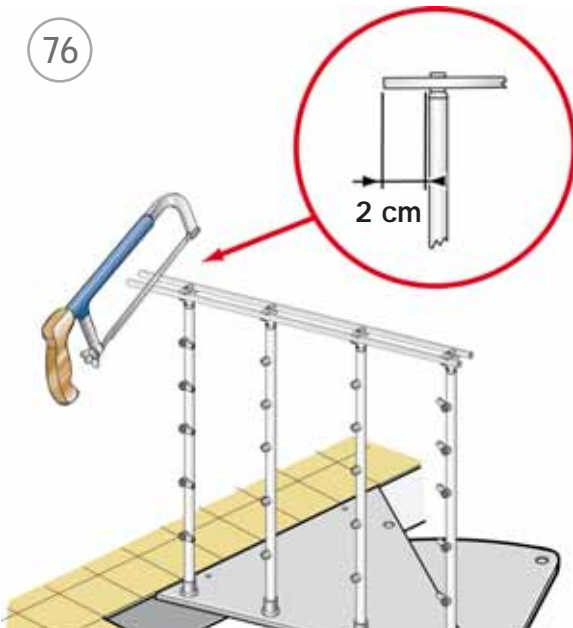

77

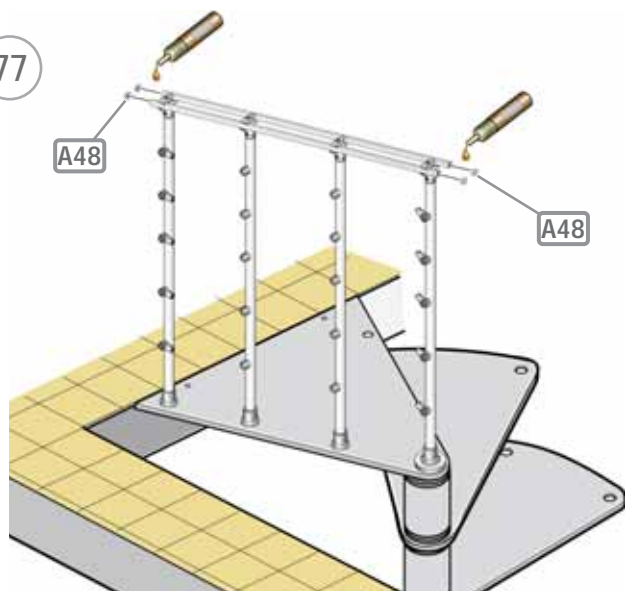

78

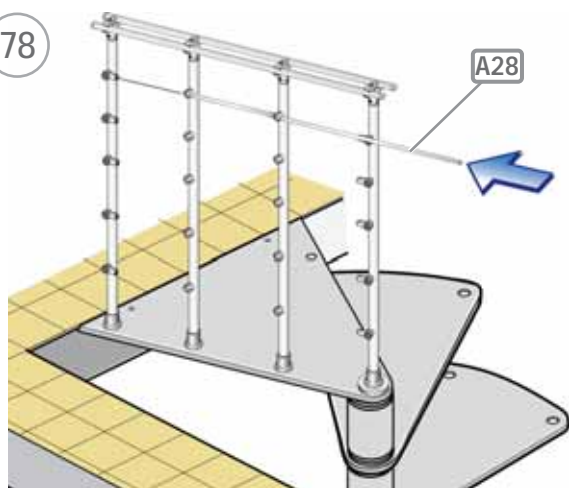

79

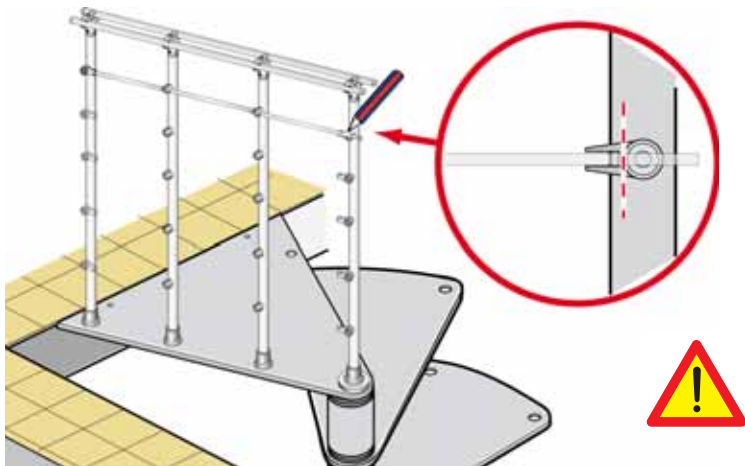

80

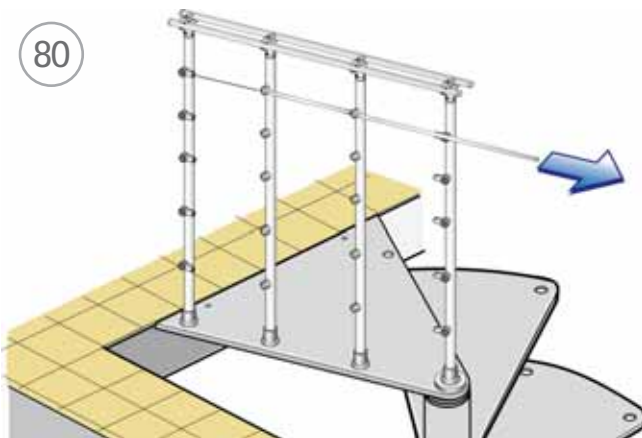

81

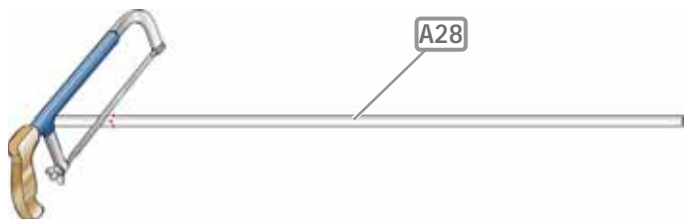

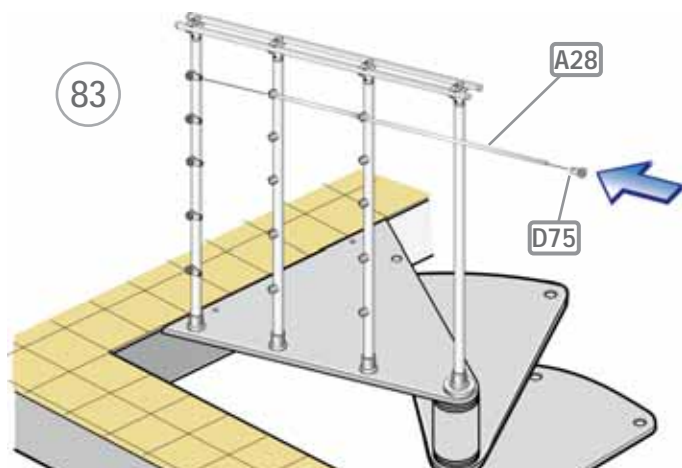
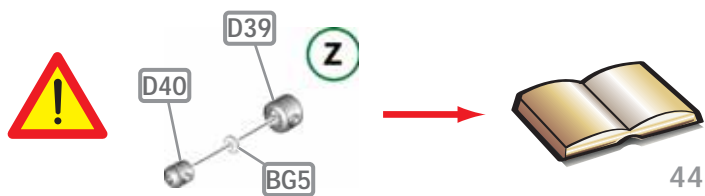
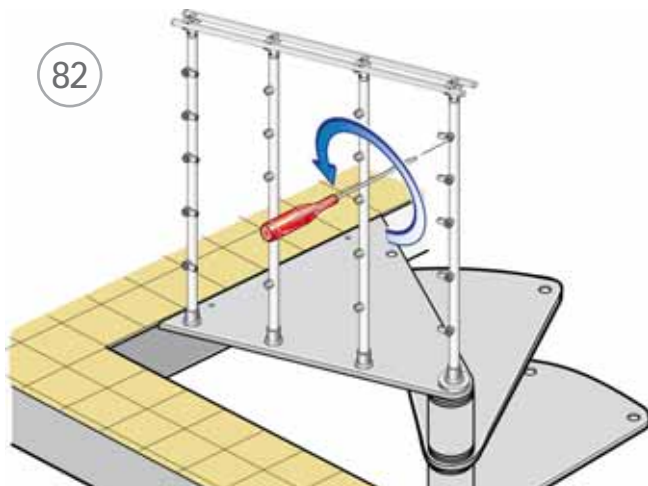

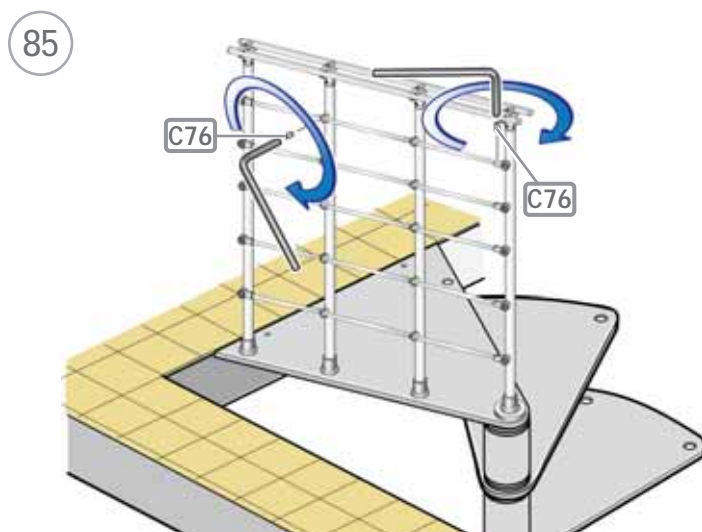
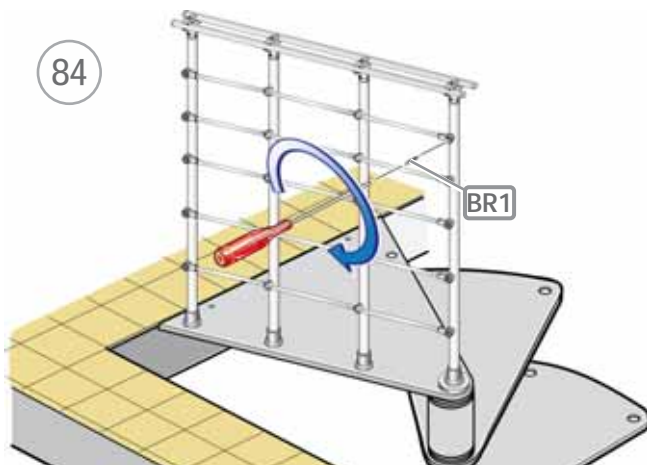

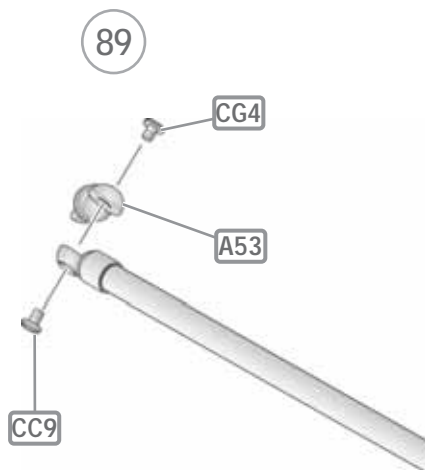
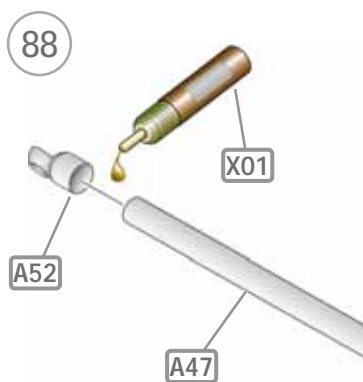
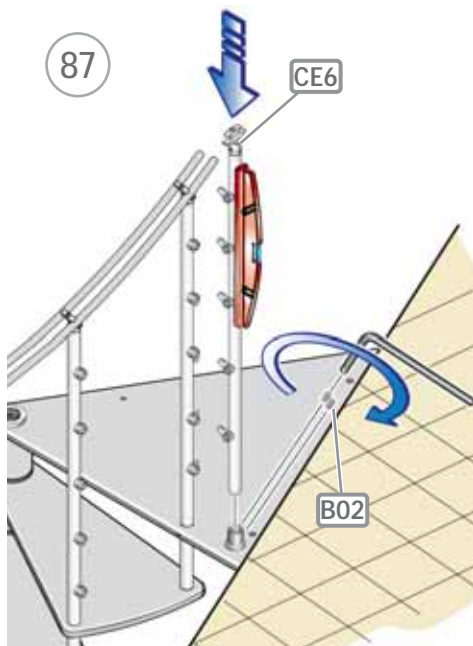
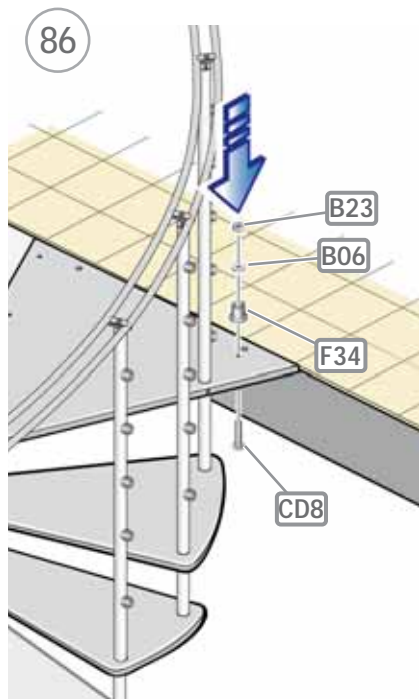

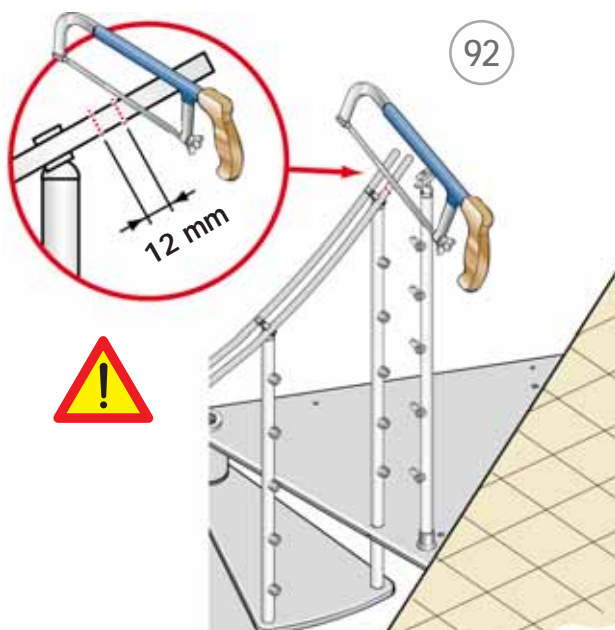
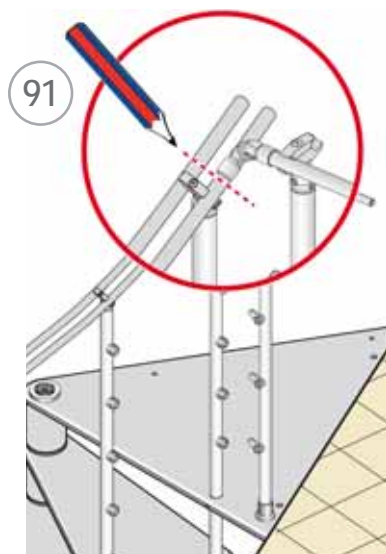
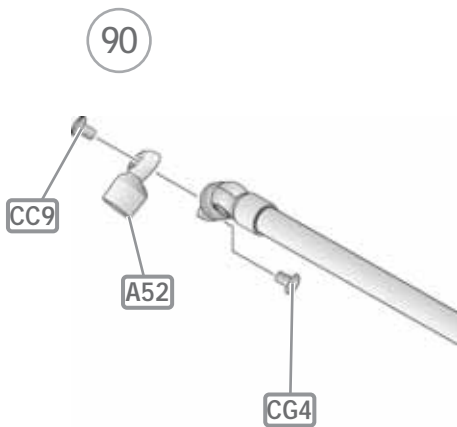

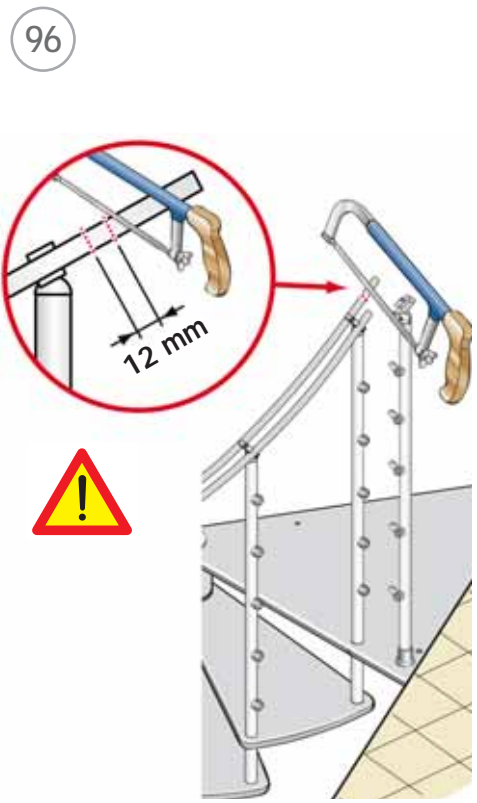
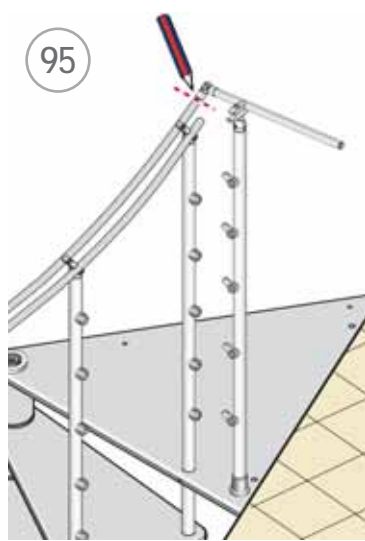
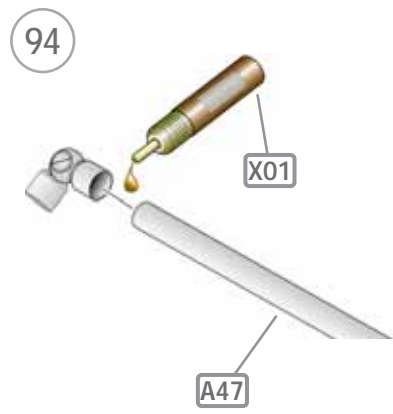
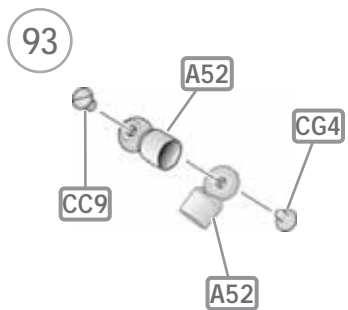

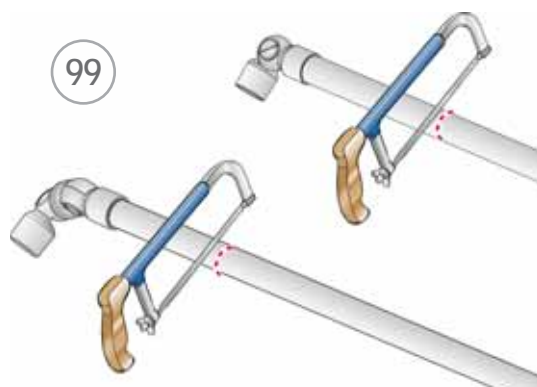
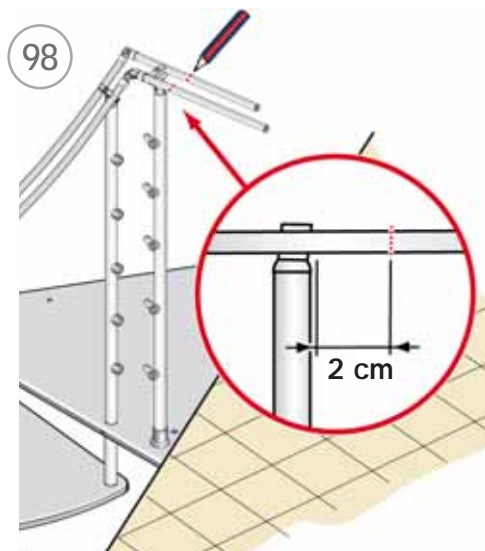
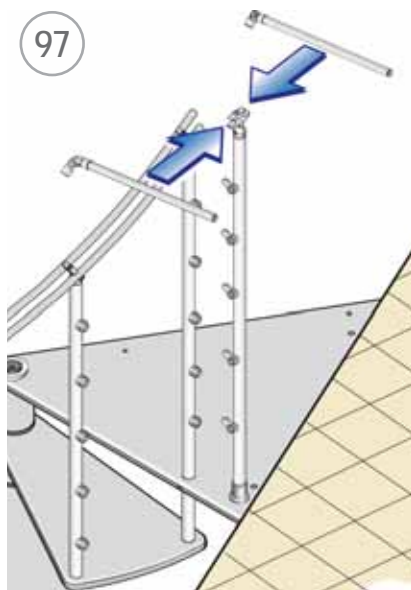

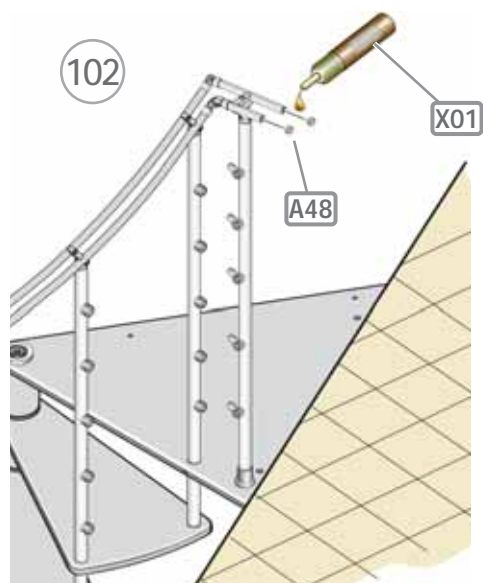
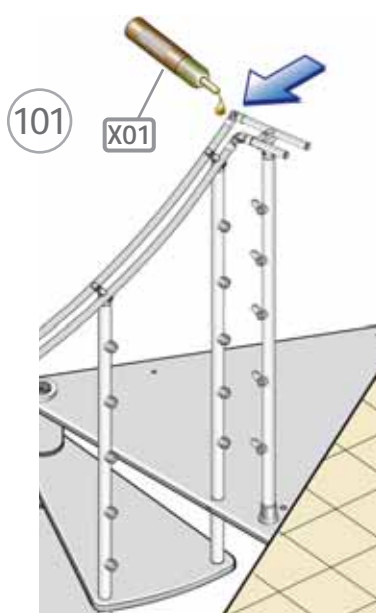
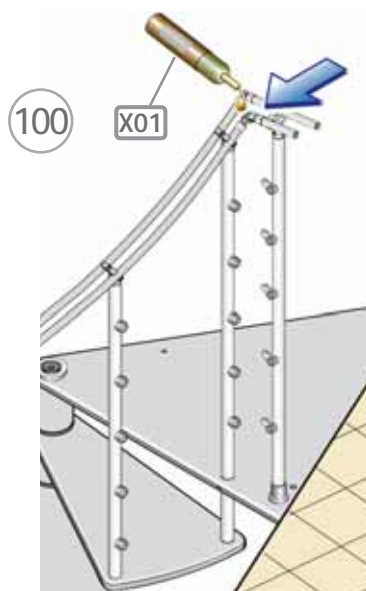

103

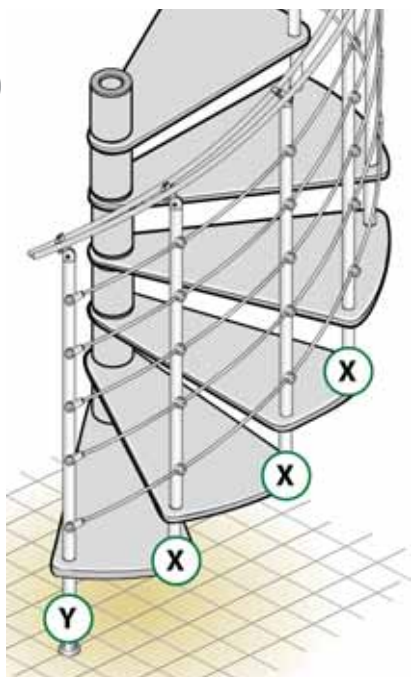

104

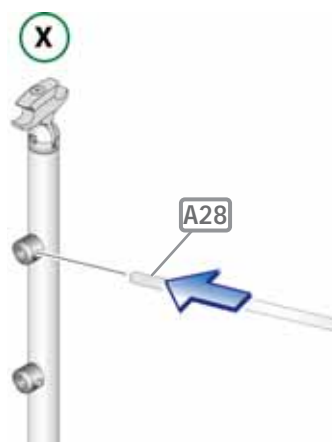

105

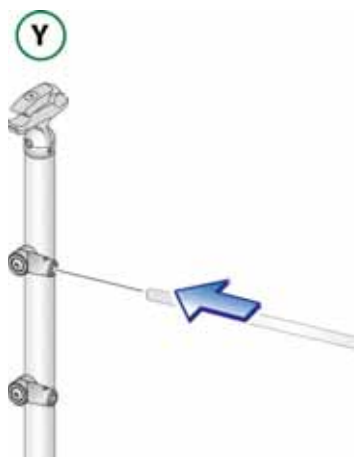

106

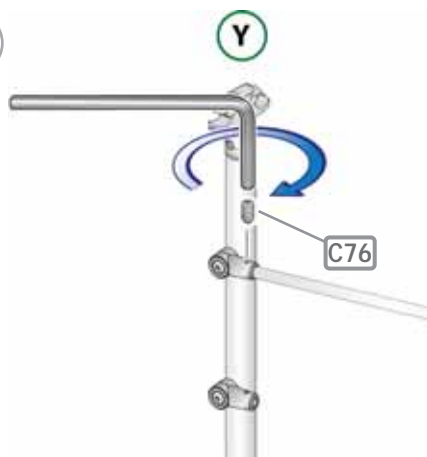

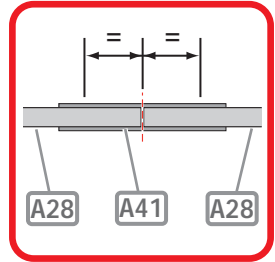
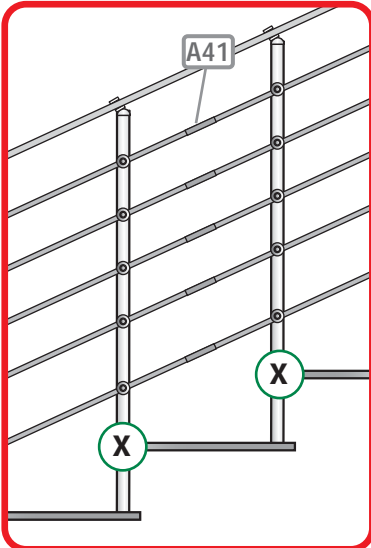
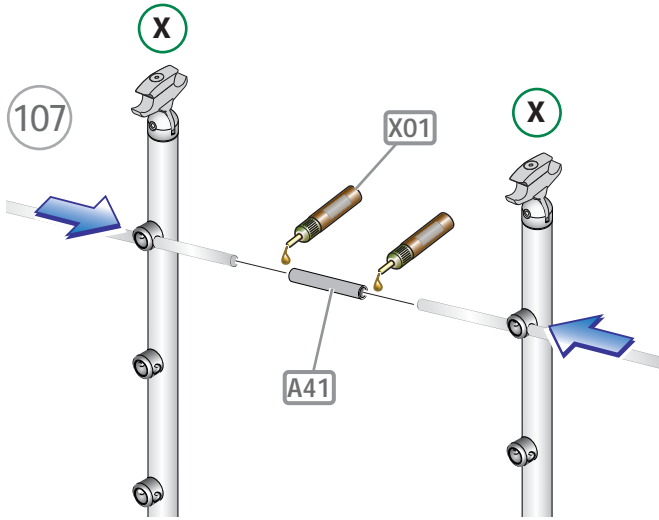

108

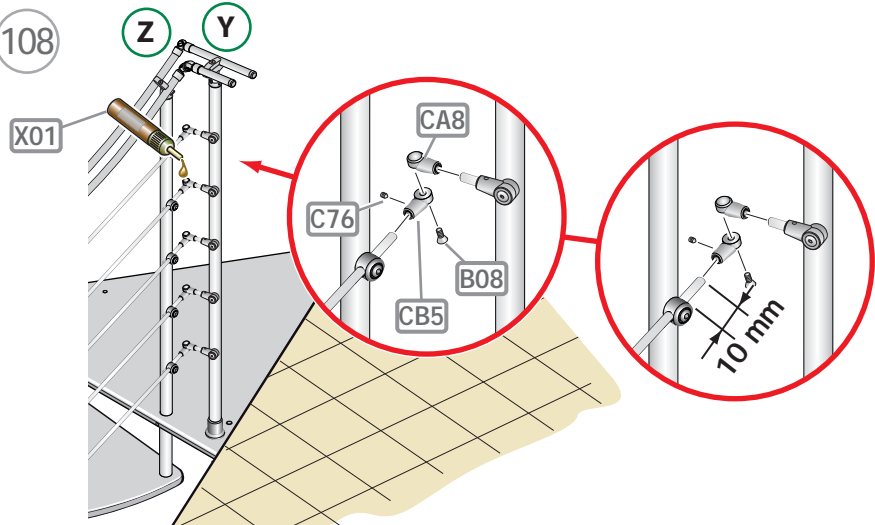

109

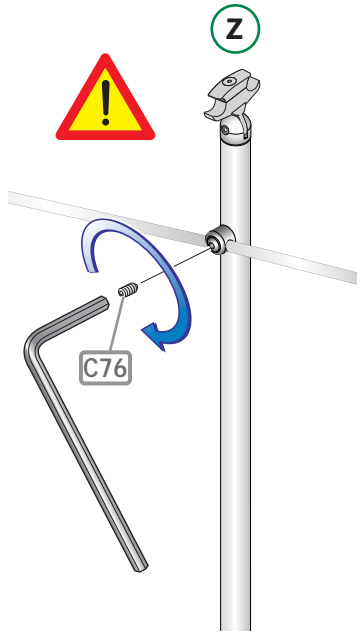

110

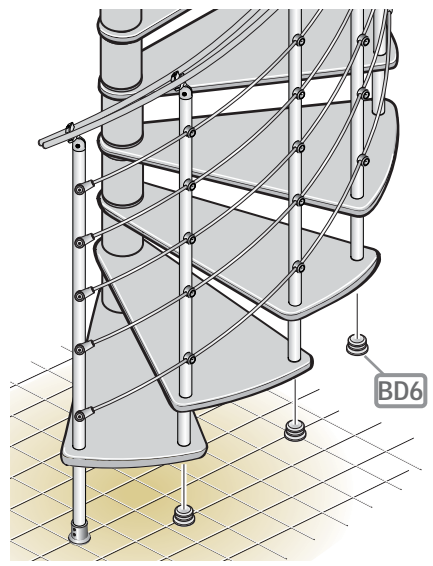

111

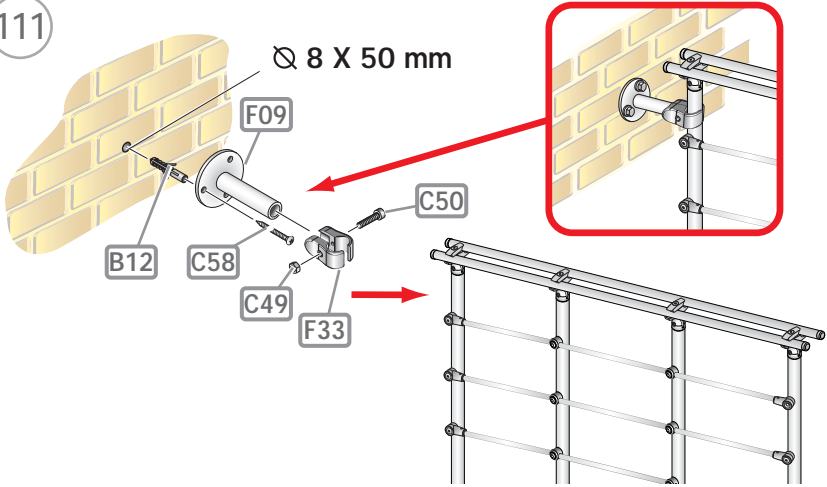

112

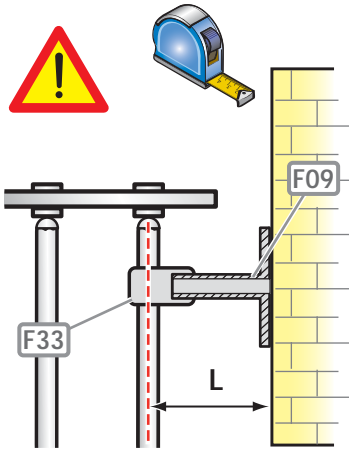

113

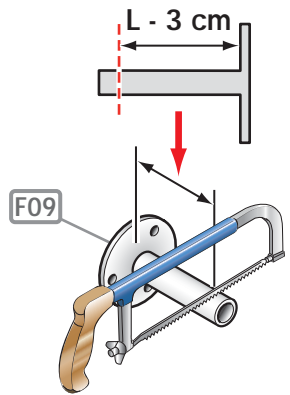

114

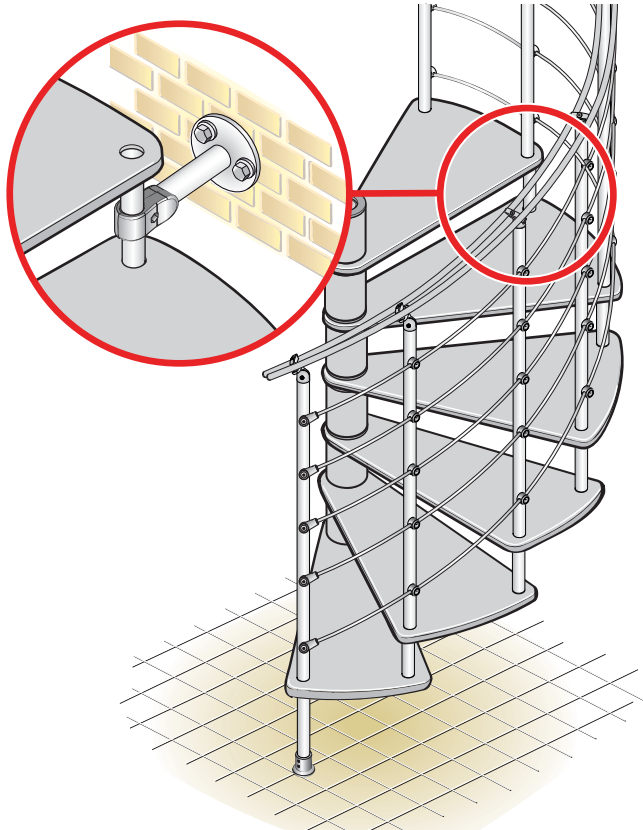

115

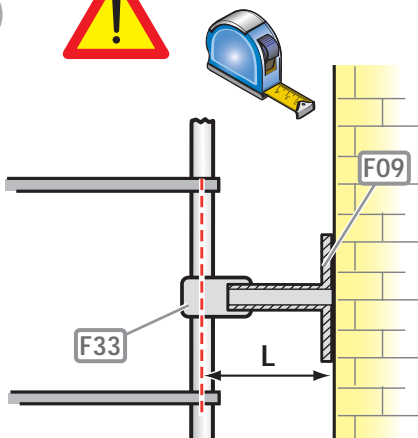



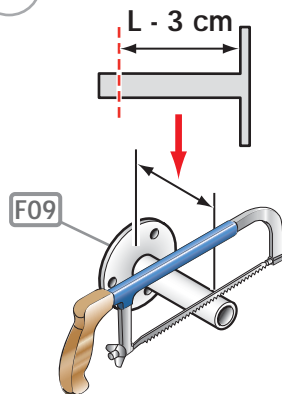

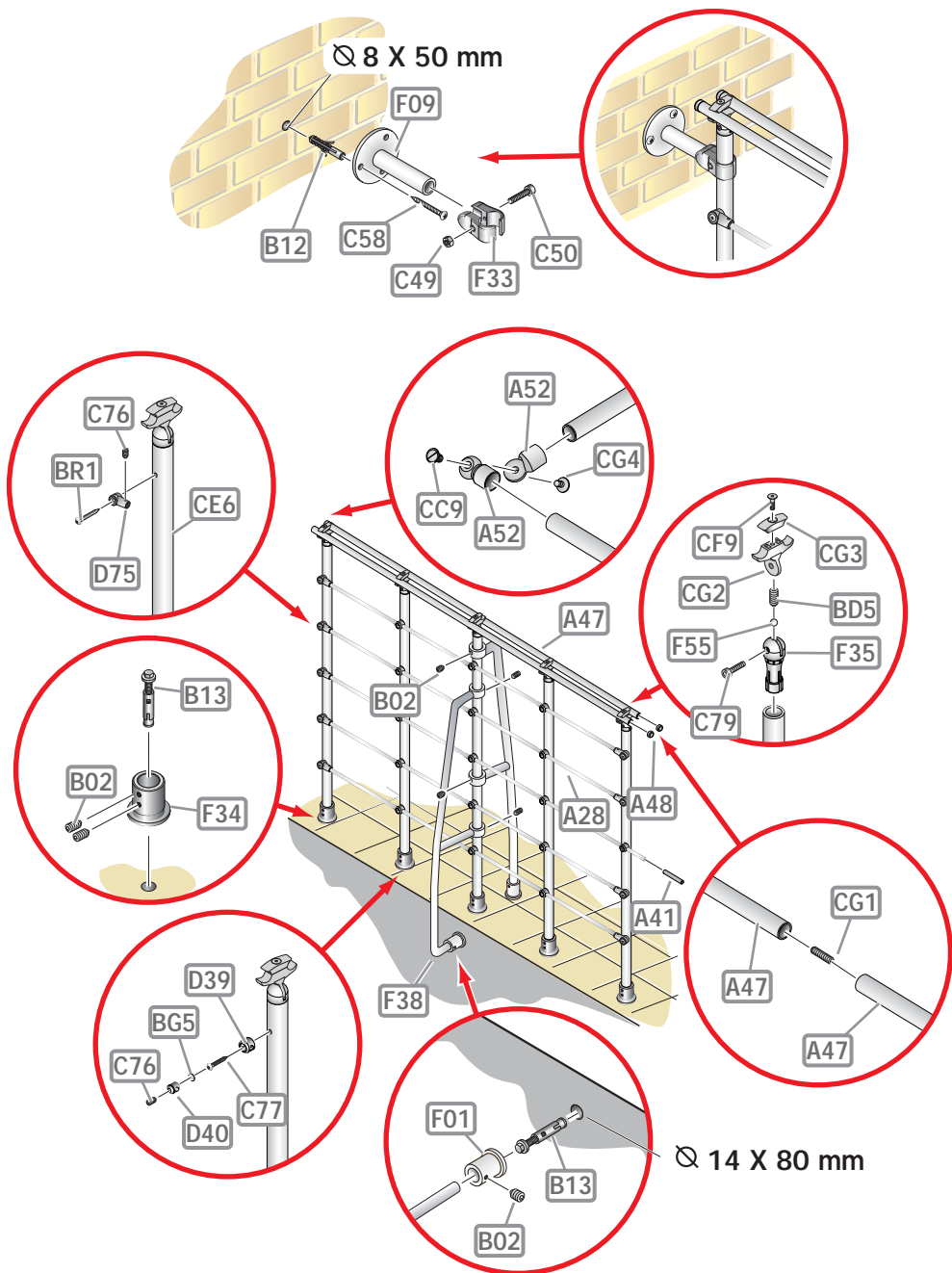

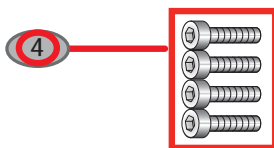



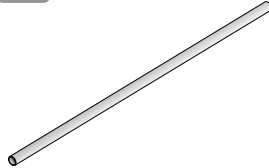

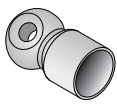
116







<p>A28</p>  <p>5</p>	<p>A41</p>  <p>5</p>	<p>A47</p>  <p>2</p>
<p>A48</p>  <p>4</p>	<p>A52</p>  <p>4</p>	<p>B02</p>  <p>13</p>
<p>B12</p>  <p>3</p>	<p>B13</p>  <p>6</p>	<p>BD5</p>  <p>5</p>
<p>BG5</p>  <p>20</p>	<p>BR1</p>  <p>10</p>	<p>C49</p>  <p>1</p>

C50



1

C58



3

C76



25

C77



20

C79



5

CC9



2

CE6

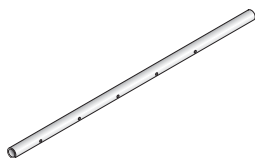

5

CF9



5

CG1



2

CG2



5

CG3



5

CG4



2

D39



20

D40







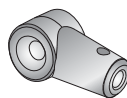

20

D75

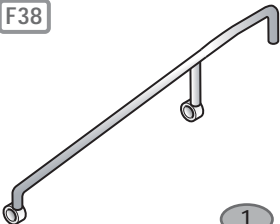

10

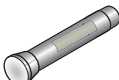
<p>F01</p>  <p>1</p>	<p>F09</p>  <p>1</p>	<p>F33</p>  <p>2</p>
<p>F34</p>  <p>5</p>	<p>F35</p>  <p>5</p>	<p>F38</p>  <p>1</p>
<p>F55</p>  <p>5</p>	<p>X01</p> 	

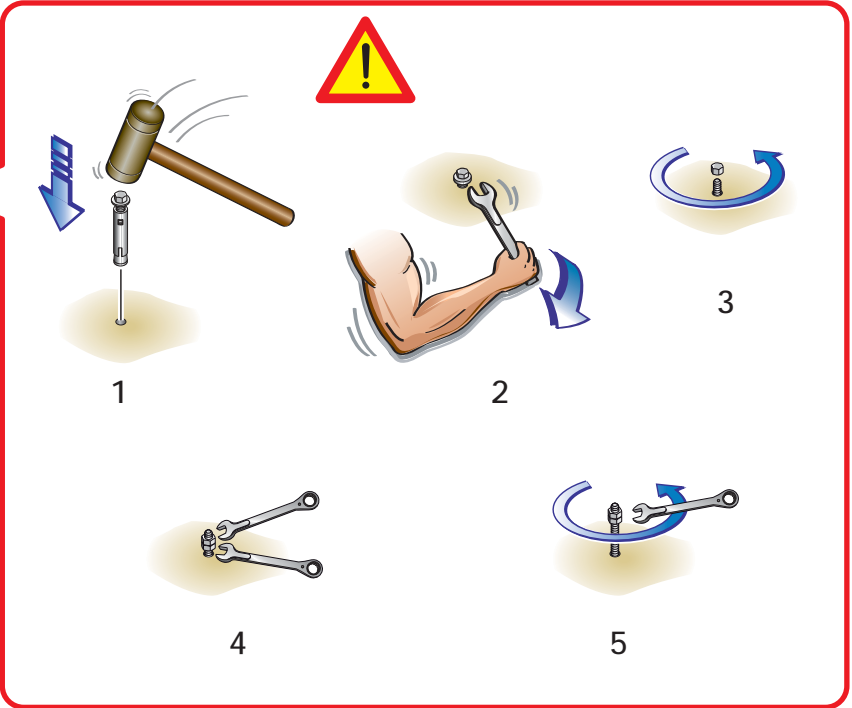
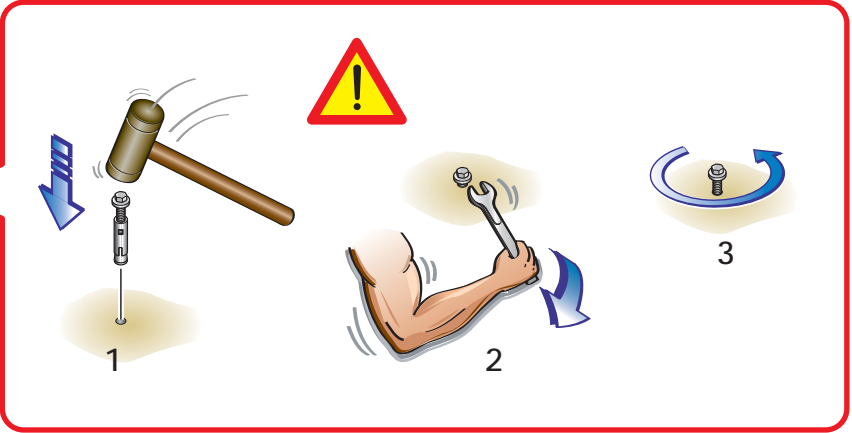



Italiano	DATI IDENTIFICATIVI DEL PRODOTTO
English	PRODUCT DETAILS
Deutsch	PRODUKTEIGENSCHAFTEN
Français	DONNÉES D'IDENTIFICATION DU PRODUIT
Español	DATOS DE IDENTIFICACIÓN
Svenska	PRODUKT DETALJER
Dansk	PRODUKTETS IDENTIFIKATIONSDATA
Norsk	PRODUKTINFORMASJON
Suomi	TUOTTEEN TUNNISTETIEDOT



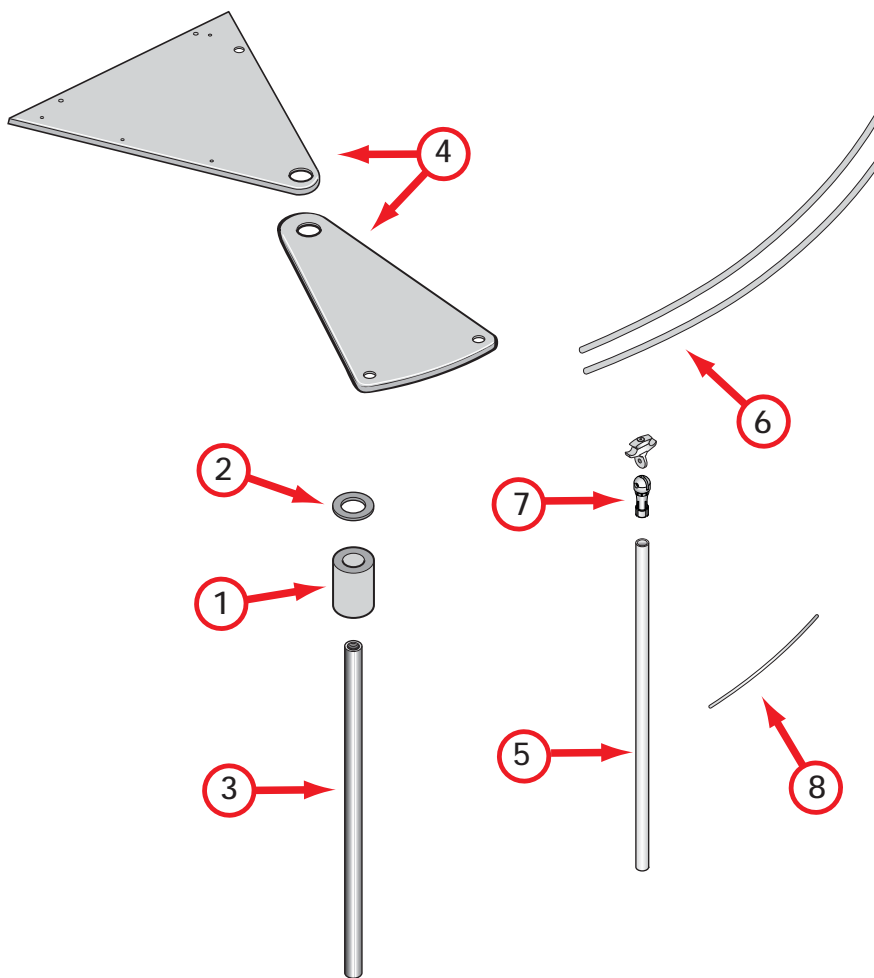

IT)

dati identificativi del prodotto

denominazione commerciale: **SLIM**

tipologia: scala a chiocciola a pianta tonda

materiali impiegati

STRUTTURA

descrizione

composta da distanziali (1) in metallo e spessori (2) in plastica impilati e compressi sul palo (3) centrale modulare

materiali

distanziali: Fe 370

spessori: nylon

palo: Fe 370 zincato

finitura

distanziali e spessori: verniciatura a forno con polveri epossidiche

GRADINI

descrizione

gradini (4) in metallo circolari impilati sul palo (3) centrale

materiali

Fe 370

finitura

verniciatura a forno con polveri epossidiche

RINGHIERA

descrizione

composta da paletti (5) verticali in metallo fissati ai gradini (4), da tondini in acciaio inox (8) e da due corrimani (6) in metallo

materiali

paletti: Fe 370

tondino: acciaio inox

corrimano: alluminio

fissaggi (7): zama

finitura

paletti, corrimano e fissaggi: verniciatura a forno con polveri epossidiche

PULIZIA E MANUTENZIONE OBBLIGATORIA

Eseguire la pulizia della scala alla prima comparsa di macchie di sporco e depositi di polvere e periodicamente almeno ogni 6 mesi con panno morbido inumidito in acqua e detergenti specifici non abrasivi ed aggressivi. NON usare mai pagliette abrasive o in ferro. Pulire ed asciugare accuratamente dopo il lavaggio con un panno in microfibra al fine di eliminare gli aloni del calcare presente nell'acqua. Dopo circa 12 mesi dalla data di installazione, controllare il serraggio della viteria dei vari componenti. Al verificarsi di qualsiasi minimo malfunzionamento è obbligatorio effettuare una manutenzione straordinaria, da eseguire subito e a regola d'arte.

PRECAUZIONI D'USO

Evitare usi impropri e non consoni al prodotto, eventuali manomissioni o installazioni non rispondenti alle istruzioni del produttore possono inficiare le conformità prestabilite del prodotto.

EN)

product details

trade name: **SLIM**

type: spiral round staircase

used materials

STRUCTURE

description

composed of metal spacers (1) and plastic spacers (2) stacked and packed on the central modular pole (3)

materials

spacers: Fe 370

plastic spacers: nylon

pole: Fe 370 galvanized

finishing

spacers: oven varnishing with epoxy powders

TREADS

description

metal circular treads (4) stacked on the central pole (3)

materials

Fe 370

finishing

oven varnishing with epoxy powders

RAILING

description

composed of metal vertical balusters (5) fixed to treads (4), of stainless steel bars (8) and of two metal handrails (6)

materials

balusters: Fe 370

bars: stainless steel

handrails: aluminium

fixings (7): zamac

finishing

balusters, handrails and fixings: oven varnishing with epoxy powders

OBLIGATORY CLEANING AND MAINTENANCE

Clean the treads as soon as dirt spots and dust deposits appear and at least every 6 months using a soft cloth moistened with water and specific nonabrasive and non-aggressive detergents. NEVER use abrasive scourers. After cleaning, thoroughly dry the surfaces with a microfibre cloth to remove the haloes that form because of the limestone in the water. Approximately 12 months from the date of installation, check tightness of the screws of the various components. Should even the smallest malfunction occur, it is obligatory to immediately and professionally carry out extraordinary maintenance.

USE PRECAUTION

Avoid any improper use that is not in accordance with the product. Possible violations or installations which don't comply with the providers instructions can invalidate the agreed product conformities.

DE)

Produkteigenschaften

kommerzielle Bezeichnung: SLIM

Typologie: Spindeltreppe mit rundem Grundriss

verwendete Materialien

STRUKTUR

Beschreibung

bestehend aus Metallstanzhülsen (1) und Distanzringen (2) aus Kunststoff um die Spindel (3) im Baukastensystem herum gestapelt und komprimiert

Materialien

Distanzhülsen: Fe 370

Distanzringe: Nylon

Spindel: Fe 370, verzinkt

Ausführung

Distanzhülsen und Distanzringe: Pulverbeschichtung mit Epoxydharzen

STUFEN

Beschreibung

runde Stufen (4) aus Metall um die Spindel (3) herum gestapelt

Materialien

Fe 370

Ausführung

Pulverbeschichtung mit Epoxydharzen

GELÄNDER

Beschreibung

bestehend aus Edelstahlängsstäben (8), senkrechten Geländerstäben (5) die auf den Stufen (4) und an zwei Handläufen (6) aus Metall befestigt sind

Materialien

Geländerstäbe: Fe 370

Längsstäben: Edelstahl

Handläufe: Aluminium

Befestigungen (7): Zamak-Legierung

Ausführung

Geländerstäbe, Handläufe und Befestigungen:

Pulverbeschichtung mit Epoxydharzen

REINIGUNG UND VORGESCHRIBENE INSTANDHALTUNG

Die Treppe sofort reinigen wenn Schmutzfl ecken und Staubansammlungen entstehen und sie mindestens alle 6 Monate mit einem weichen, mit Wasser und einem spezifischen, weder scheuernden, noch aggressiven Reinigungsmittel befeuchteten Lappen abwischen. NIEMALS scheuernde Eisenschwämme verwenden. Nach der Feuchtreinigung mit einem Mikrofaser Tuch sorgfältig nachtrocknen, um die Schlierenbildung durch kalkhaltiges Wasser zu vermeiden. 12 Monate nach der Montage das Anzugsmoment der Schrauben der verschiedenen Komponenten kontrollieren. Bei Auftreten einer noch so geringen Funktionsstörung muss unbedingt sofort eine fachgerechte außerordentliche Instandhaltung durchgeführt werden.

VORSICHTSMAßNAHMEN FÜR DIE ANWENDUNG

Die falsche und unangemessene Verwendung des Produkts vermeiden. Eventuelle Beschädigungen oder nicht der Montageanleitung des Herstellers gemäße Einrichtungen können die vorgegebene Produktkonformität für ungültig erklären.

FR)

données d'identification du produit

denomination commerciale : SLIM

typologie : escalier hélicoïdal à plan rond

matériaux utilisés

STRUCTURE

description

composée de entretoises (1) en métal et cales (2) en plastique empilées et comprimées sur le pylône (3) modulaire central

matériaux

entretoises : Fe 370

cales : nylon

pylône : Fe 370 galvanisé

finition

entretoises et cales : vernissage à chaud avec poudres époxy

MARCHES

description

marches (4) en métal circulaires empilées sur le pylône (3) central

matériaux

Fe 370

finition

vernissage à chaud avec poudres époxy

GARDE-CORPS

description

composé de colonnettes (5) verticales en métal fixées aux marches (4), de lisses en acier inox (8) et deux main courantes en métal (6)

matériaux

colonnettes : Fe 370

lisses : acier inox

main courantes : aluminium

fixations (7) : zamak

finition

colonnettes, main courantes et fixations: vernissage à chaud avec poudres époxy

NETTOYAGE ET MAINTENANCE OBLIGATOIRE

Nettoyer les marches dès que des taches de saleté ou des dépôts de poussière apparaissent ; effectuer également un nettoyage périodique, tous les 6 mois, à l'aide d'un chiffon doux, humidifié d'eau et de détergents spécifiques non abrasifs et non agressifs. NE JAMAIS utiliser de la paille de fer abrasive. Après lavage, nettoyer et essuyer soigneusement avec un chiffon en microfibre, afin d'éliminer les auréoles provoquées par le calcaire contenu dans l'eau. Environ 12 mois après la date d'installation, contrôler le serrage des vis des différents composants. À la moindre défaillance, il est obligatoire d'effectuer immédiatement une maintenance corrective, dans les règles de l'art.

PRECAUTION D'UTILISATION

Eviter l'utilisation impropre et non conforme au produit. D'éventuelles alterations ou installations non correspondantes aux instructions du producteur peuvent invalider les conformités préétablies du produit.

ES) datos de identificación del producto

denominación comercial: **SLIM**

tipo: escalera de caracol de planta redonda

materiales empleados

ESTRUCTURA

descripción

compuesta por distanciadores (1) de metal y espaciadores (2) de plástico enfilados y comprimidos en la columna (3) central modular

materiales

distanciadores: Fe 370

espaciadores: nylon

columna central: Fe 370 galvanizado

acabado

distanciadores y espaciadores: barnizado en horno con polvos epoxídicos

PELDAÑOS

descripción

peldaños (4) de metal circulares enfilados en la columna (3) central

materiales

Fe 370

acabado

barnizado en horno con polvos epoxídicos

BARANDILLA

descripción

compuesta por barrotes (5) verticales de metal fijados a los peldaños (4), por barras de acero inoxidable (8) y por dos pasamanos (6) de metal

materiales

barrotes: Fe 370

barras: acero inoxidable

pasamanos: aluminio

fijaciones (7): zamak

acabado

barrotes, pasamanos y fijaciones: barnizado en horno con polvos epoxídicos

LIMPIEZA Y MANTENIMIENTO OBLIGATORIO

Realizar la limpieza de la escalera en cuanto aparezcan manchas de suciedad y depósitos de polvo, y periódicamente al menos cada 6 meses, con un paño suave humedecido en agua y detergentes específicos no abrasivos ni agresivos. NO utilizar nunca lanas abrasivas o de hierro. Limpiar y secar bien después del lavado utilizando un paño de microfibra para eliminar las aureolas de cal dejadas por el agua. Transcurridos unos 12 meses desde la fecha de instalación, comprobar que los tornillos que fijan las distintas partes sigan bien apretados. Ante el menor defecto de funcionamiento, es obligatorio realizar un mantenimiento extraordinario según las reglas del arte.

PRECAUCIONES DE USO

Evitar usos impropios y no conformes con el producto. Eventuales manipulaciones o instalaciones que no cumplan con las instrucciones del fabricante pueden menoscabar las cualidades certificadas en las pruebas de conformidad a las que previamente fue sometido el producto.

SV) produkt detaljer

varunamn: **SLIM**

typ: rund spiral trappa

material

KONSTRUKTIONEN

beskrivning

bestående av mellanlägg (1) av metall och distanshållare (2) av plast som staplas och pressas samman på den centrala modulstolpen (3)

material

mellanlägg: Fe 370

distanshållare: nylon

stolpe: Fe 370 förzinkad

ytbehandling

mellanlägg och distanshållare: ugnslackerade med epoxipulver

TRAPPSTEG

beskrivning

runda trappsteg (4) av metall som staplas på central stolpe (3)

material

Fe 370

ytbehandling

ugnslackerade med epoxipulver

RÄCKE

beskrivning

bestående av vertikala stolpar (5) av metall som sitter fast på trappstegen (4) kablarna av rostfritt stål (8) och två metall handledare (6)

material

stolpar: Fe 370

kablarna: rostfritt stål

handledare: aluminium

fästanordningar (7): zama

ytbehandling

stolpar, handledare och fästanordningar:

ugnslackerade med epoxipulver

NÖDVÄNDIG RENGÖRING OCH UNDERHÅLL

Rengör trappan vid första smutsfläck eller när damm samlas, och regelbundet minst var 6:e månad. Rengör med en trasa fuktad med vatten och lämpligt rengöringsmedel som inte är slipande eller frätande. Använd aldrig slipande svampar eller stålull. Rengör och torka noggrant efter rengöring med en mikrofiberduk för att undvika kalkfläckar från vattnet. Kontrollera åtdragningen av skruvarna för de olika komponenterna efter 12 månader. Vid varje typ av felfunktion är det obligatoriskt att utföra ett extra underhåll. Detta ska utföras omedelbart och på ett yrkesmannamässigt sätt.

ANVÄNDNINGSFÖRESKRIFTER

Undvik att använda produkten på ett olämpligt sätt. Eventuell mixtring eller installation som inte överensstämmer med tillverkarens anvisningar kan leda till att överensstämmelsekraven som har fastställts för produkten inte längre gäller.

DA) produktets identifikasjonsdata

handelsbetegnelse: SLIM

type: vindeltrappe med rundt skema

brugte materialer

STRUKTUREN

beskrivelse

strukturen består af afstandsstykker (1) i metal og plastikpakninger (2) indsat oven på hinanden og komprimert på den midterste modulstolpe (3)

materialer

afstandsstykker: Fe 370

pakninger: nylonplastik

stolpe: Fe 370 forzinket

finish

afstandsstykker og pakninger: malet i ovn med epoxyulver

TRIN

beskrivelse

cirkulære metaltrin (4) indsat oven på hinanden på centralstolpen (3) beklædt

materialer

Fe 370

finish

malet i ovn med epoxyulver

GELÆNDER

beskrivelse

bestående af vertikale balustre (5) i metal fastgjort til trinene (4) med et rundjern i rustfri stål (8) og to metall håndliste (6)

materialer

balustre: Fe 370

rundjern: rustfri stål

håndliste: aluminium

fastgøringer (7): zamak

finish

balustre, håndliste og fastgøringer: malet i ovn med epoxyulver

RENGØRING OG PÅBUDT VEDLIGEHOOLDSE

Trappen skal rengøres når de første tegn på tilsmudsning og af støvaflejringer fremkommer, og i hvert fald regelmæssigt for hver 6. måned med en blød klud vædet i vand og specifikke ikke ætsende eller aggressive rengøringsmidler. Der må ALDRIG bruges skure- eller stålsvampe. Rengør og tør omhyggeligt med en mikrofiberklud efter vask for at fjerne kalkaflejringerne, der findes i vandet. Efter ca. 12 måneder fra installationsdatoen, kontrolleres fikseringen på de forskellige komponenters skruer. I tilfælde af en hvilken som helst fejlfunktion, er det påbudt at udføre en ekstraordinær vedligeholdelse, der bør udføres omgående og i overensstemmelse med bedste praksis.

FORHOLDSREGLER VED BRUG

Undgå ukorrekt brug, som produktet ikke er beregnet til. Eventuelle ændringer eller installationer, som ikke stemmer overens med producentens anvisninger, kan påvirke produktets overensstemmelse som fastsat inden brug.

NO) produktinformasjon

produktnavn: SLIM

karakteristikk: spiraltrapp med sirkulært plan

produksjonsmaterialer

STRUKTUR

beskrivelse

sammensatt av avstandsholdere (1) i metall og avstandsstykker (2) i plast, stablet lagvis og komprimert på modulens midtstolpe (3)

materialer

avstandsholdere: Fe 370

avstandsstykker: nylon

stolpe: Fe 370 galvanisert

finish

avstandsholdere og avstandsstykker: ovnslakkert med epoksyulver

TRAPPETRINN

beskrivelse

sirkulære trappetrinn (4) i metall, stablet lagvis på midtstolpen (3)

materialer

Fe 370

finish

ovnslakkert med epoksyulver

REKKVERK

beskrivelse

sammensatt av loddrette spiler i metall (5) som er festet i trappetrinnene (4), rustfrie stengene (8) og to metall håndrekke (6)

materialer

spiler: Fe 370

stengene: rustfritt stål

håndrekke: aluminium

fester (7): zamak

finish

spiler, håndrekke og fester: ovnslakkert med epoksyulver

RENGØRING OG NØDVENDIG VEDLIGEHOOLD

Rengjør trappen straks det oppstår flekker eller støvansamlinger. Trappen må dessuten rengjøres jevnlig minst hver 6. måned med en myk klut fuktet med vann og spesielle milde rengjøringsmidler som ikke lager riper. Bruk IKKE rengjøringsssvamper med slipeeffekt eller stålull. Skyll og tørk omhyggelig med en mikrofiberklud etter rengjøringen, slik at alle kalkholdige vannflekker fjernes. Kontroller etter ca. 12 måneder fra installasjonen, at skruene i de forskjellige komponentene er korrekt strammet. Så snart man oppdager den minste funksjonsfeil må det utføres et forskriftsmessig ekstraordinært vedlikeholdsinngrep.

FORHOLDSREGLER VED BRUK

Unngå u riktig og uegnet bruk av produktet. Eventuelle endringer eller installasjoner som ikke er i samsvar med produsentens anvisninger vil kunne medføre at de forhåndsdefinerte produktkonformitetene ugyldiggjøres.

FI)

tuotteen tunnistetiedot

kauppanimi: SLIM

tyyppi: pyöreä kierreporras

käytetyt materiaalit

RAKENNE

kuvaus

koostuu metallisista välilevyistä (1) ja muovisista välilevyistä (2), jotka kasataan ja painetaan modulaariseen keskipylvääseen (3)

materiaalit

välilevyt: Fe 370

muoviset välilevyt: nailon

pylväs: sinkitty Fe 370

viimeistely

välilevyt ja muoviset välilevyt: maalaus uunissa epoksijauheilla

ASKELMAT

kuvaus

metalliset kiertyvät askelmat (4) pinottu keskipylvääseen (3)

materiaalit

Fe 370

viimeistely

maalaus uunissa epoksijauheilla

KAIDE

kuvaus

koostuu askelmiin (4) kiinnitetyistä metallisista pystypinnoista (5) sekä ruostumatonta terästä olevista terästangot (8) ja kaksi metalli käsijohdetta (6)

materiaalit

pystypinnat: Fe 370

kaapelit: ruostumaton teräs

käsijohde: alumiini

kiinnikkeet (7): zamak

viimeistely

pystypinna, käsijohde ja kiinnikkeet: maalaus uunissa epoksijauheilla

PAKOLLINEN PUHDISTUS JA YLLÄPITO

Huolehdi portaiden puhdistuksesta ensimmäisten likatahrojen tai pölyjäämien ilmestyessä sekä säännöllisin väliajoin vähintään joka 6. kuukausi liinalla, joka on kostutettu miedon hankaamattoman pesuaineen ja veden muodostamassa liuoksessa. ÄLÄ koskaan käytä hankaavia tai metallisia sieniä. Puhdista ja kuivaa huolellisesti pesun jälkeen mikrokuituliinalla, jotta poistetaan vesijäämien aikaansaamat kalkkiläikät. Noin 12 kuukauden kuluttua asennuksesta tarkista, että kaikki eri osien ruuvit ja mutterit ovat tiukalla. Mikäli havaitaan pienikin toimintahäiriö, on pakollista suorittaa ennakoimaton huolto, välittömästi ja tarvittavat toimenpiteet kunnolla suorittaen.

KÄYTÖN VAROTOIMET

Vältä tuotteen sopimatonta käyttöä. Mahdolliset väärinkäytökset tai asennukset, jotka eivät vastaa valmistajan ohjeita, voivat aiheuttaa sen, ettei tuote vastaa sen ilmoitettuja ominaisuuksia.



SLIM
D.U.M.
10/2015

fontanot®

Fontanot S.p.A.
Sede legale ed amministrativa
via P. Paolo Pasolini, 6
47853 Cerasolo Ausa
Rimini, Italy

tel. +39.0541.90.61.11
fax. +39.0541.90.61.24
info@fontanotshop.com
www.fontanotshop.com

cod. 067127001

Design: Centro Ricerche Fontanot

ADMEMBER

Sistema aziendale Fontanot S.p.A.
certificato CSQ ISO-9001

